

PHASE PERFECT[®]

240V & 480V *Digital Phase Converter*

Operation & Installation Manual

- Single-Phase to Three-Phase
- Solid State Technology
- 95 - 98.7% Efficient



Product Manual

PHASEPERFECT® Digital Phase Converter



222 Disk Drive
Rapid City, SD 57702

Phone: 605-343-7934
Fax: 605-343-7943
Toll Free: 866-250-7934

www.phasetechnologies.com



2022 © Copyright. V2.4 All rights reserved. All contents are property of Phase Technologies, LLC.

No portion of this publication or its contents may be duplicated by any means, electronic or otherwise, without the express written consent of Phase Technologies, LLC.

V2.4_02212022

INTRODUCTION

The Phase Perfect® Digital Phase Converter converts single-phase AC power to three-phase AC power to operate a variety of electrical equipment. The Phase Perfect® delivers unmatched, three-phase voltage balance and operates at 98.7% efficiency.

Output voltage is sinusoidal with low harmonic content, making it safe to operate sensitive electronic equipment. The Phase Perfect® was designed to comply with IEEE 519 to meet utility regulatory standards.


Phase Perfect® Digital Phase Converters are available in NEMA 1 indoor enclosures and NEMA 3R outdoor enclosures with insect guards.





SAFETY MESSAGES AND WARNINGS

To ensure safe and reliable operation of the Phase Perfect®, it is important to carefully read this manual and to observe all warning labels attached to the unit before installing. Please follow all instructions exactly and keep this manual with the unit for quick and easy reference.


Definitions of Warning Signs and Symbols


 **CAUTION:** Indicates a potentially hazardous situation that could result in injury or damage to the product.


 **WARNING:** Indicates a potentially hazardous situation that could result in serious injury or death.


 **HIGH VOLTAGE:** The voltage associated with the procedures referenced could result in serious injury or death. Use caution and follow instructions carefully.


READ THESE WARNINGS BEFORE INSTALLING OR OPERATING EQUIPMENT!


 **WARNING:** Risk of electric shock. More than one disconnect switch may be required to de-energize the equipment before servicing.


 **WARNING:** Risk of electric shock. De-energize the unit by disconnecting all incoming sources of power, then wait 30 minutes for internal charges to dissipate before servicing the equipment.


 **HIGH VOLTAGE:** This equipment is connected to line voltages that can create a potentially hazardous situation. Electric shock could result in serious injury or death. This device should be installed and serviced only by trained, licensed, and qualified personnel. Follow instructions carefully and observe all warnings.

 **WARNING:** Installation of this equipment must comply with the National Electrical Code (NEC) and all applicable local codes. Failure to observe and comply with these codes could result in risk of electric shock, fire, or damage to the equipment.


 **CAUTION:** Circuit breakers, fuses, proper ground circuits, and other safety equipment and their proper installation are not provided by Phase Technologies, LLC, and are the responsibility of the end user.


 **CAUTION:** Failure to maintain adequate clearance may lead to overheating of the unit and cause damage or fire.


 **WARNING:** Input power connections should be made by a qualified electrician into circuit with adequate voltage and current carrying capacity for the model. Branch circuit protection to the unit should be provided by appropriately sized fuses or a 2-pole circuit breaker.

 **CAUTION:** Use 600 V vinyl-sheathed wire or equivalent. The voltage drop of the leads needs to be considered in determining wire size. Voltage drop is dependent on wire length and gauge. Use only copper conductors.

 **CAUTION:** Wires fastened to the terminal blocks shall be secured by tightening the terminal screws to a torque value listed in **Table 14 - Table 17**.

 **CAUTION:** The input wire gauge must be sized for the single-phase input current, which will be significantly larger than the three-phase output current to the load. The minimum wire gauge for the input terminals is listed in **Table 13**.

 **CAUTION:** Never allow bare wire to contact metal surfaces.

 **CAUTION:** Never connect AC main power to the output terminals T1, T2, and T3.


 **WARNING:** Under certain conditions, the motor load may automatically restart after a trip has stopped it. Make sure power to the converter has been disconnected before approaching or servicing the equipment. Otherwise, serious injury may occur.

TABLE OF CONTENTS

THEORY OF OPERATION	1
BLOCK DIAGRAM.....	1
MODELS AND RATINGS	2
SPECIFICATIONS	3
GENERAL SPECIFICATIONS	3
ELECTRICAL SPECIFICATIONS	3
MECHANICAL SPECIFICATIONS	5
DIMENSIONAL DRAWINGS	7
INSTALLATION.....	13
MOUNTING YOUR NEW PHASE PERFECT	13
MOUNTING BRACKET INSTALLATION	13
PROPER VENTILATION	13
SERVICE ENTRANCE EQUIPMENT	13
SOURCE BRANCH CIRCUIT PROTECTION.....	13
GROUNDING	14
WIRE SIZING	16
CONNECTING THE LOAD	16
CONNECTING TO FIELD WIRING TERMINALS	19
ROUTING POWER CABLES	21
ON/OFF CONTROL WIRING.....	22
OPERATION.....	24
LCD STATUS SCREEN.....	24
DIP SWITCH SETTINGS	24
BYPASS AUX INPUTS.....	25
ENABLE VFD MODE.....	25
VOLTAGE CALIBRATION	25
TRANSFORMER MODE	26
ELEVATOR MODE.....	27
STARTUP DELAY	28
INFINITE RESTARTS.....	29
FAULT CODES	30
FAULTS: MANUAL RESTART	30
FAULT LOG.....	31
TROUBLESHOOTING TIPS	32
ROUTINE INSPECTION AND MAINTENANCE	33
LINE FILTER CAPACITORS.....	33
FUSES	36
MOTOR STARTING/OVERLOAD CAPABILITIES	38
WARRANTY POLICY	41

THEORY OF OPERATION

L1 and L2 of the single-phase input pass directly through the phase converter to provide two legs of the three-phase output. The input module charges a DC bus from the input lines. The output module uses power from the DC bus to generate the third leg of the three-phase output. The third leg is generated to limit voltage imbalance between the three legs to $\leq 2\%$. Voltage imbalance is calculated according to the NEMA MG1 standard.

$$V_{ib} = \frac{V_{\max\ difference}}{V_{avg}}$$

Where:

$$V_{avg} = \frac{V_{T1T2} + V_{T2T3} + V_{T3T1}}{3}$$

$$V_{\max\ difference} = \text{MAX of } (|V_{T1T2} - V_{avg}|, |V_{T2T3} - V_{avg}|, |V_{T3T1} - V_{avg}|)$$

Block Diagram

The diagram in **Figure 1** illustrates the basic design schematic of the Phase Perfect Digital Phase Converter.

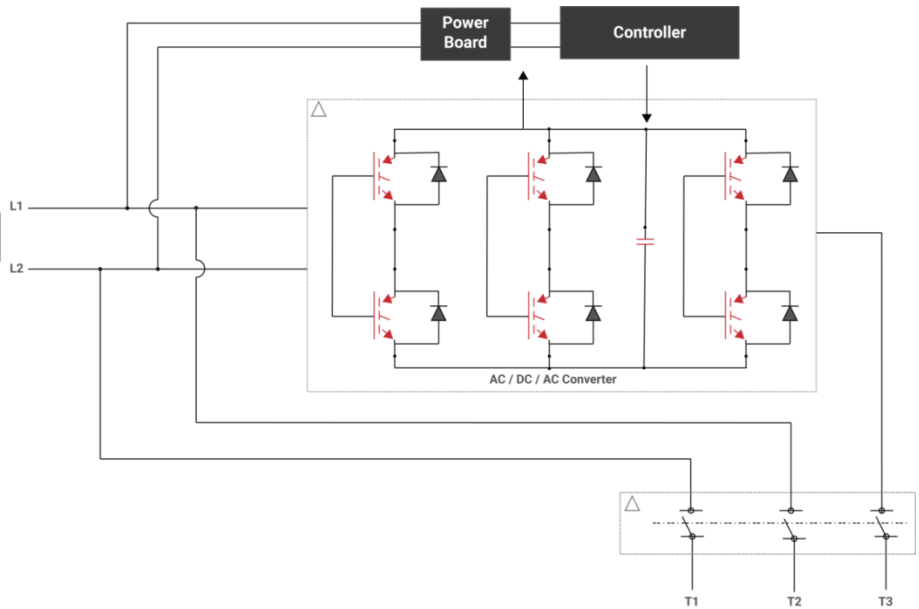


Figure 1 – Phase Perfect Digital Phase Converter Schematic

MODELS AND RATINGS

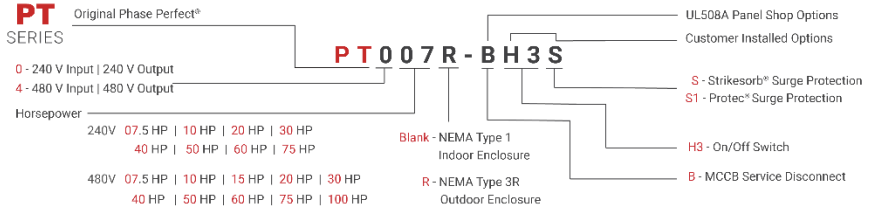


Figure 2 – Phase Perfect Nomenclature

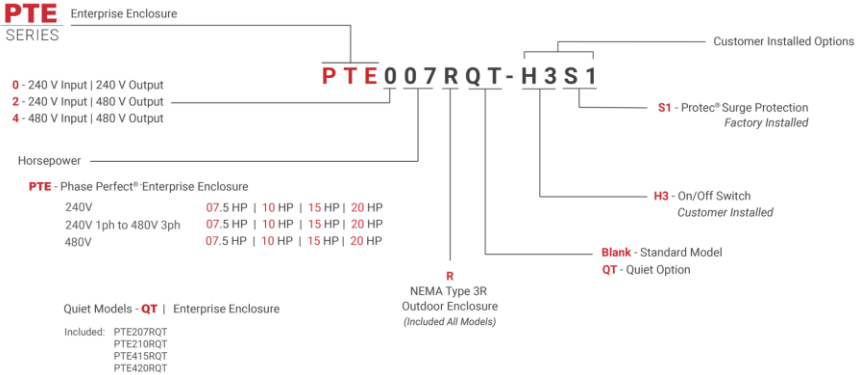


Figure 3 – Phase Perfect Enterprise Nomenclature

SPECIFICATIONS

General Specifications

Table 1 – General Specifications

Output Voltage – Standard Models	Approx. equal to input voltage
Output Voltage – Voltage Doubling Models	Approx. 2 x input voltage
Output Voltage Imbalance	≤2%
Operating Temperature – PT	-10°C (14°F) to 50°C (122°F)
Operating Temperature – PTE	-10°C (14°F) to 40°C (104°F)
Storage Temperature	-20°C (-4°F) to 60°C (140°F)
Efficiency – Standard Models	98.7%
Efficiency – Voltage-Doubling Models	95.0%
Short Circuit Withstand Rating	10kA
Audible Noise – PT Models	75 dBA
Audible Noise – PTE Models	80 dBA
Audible Noise – PTE “QT” Models	75 dBA
Start Delay on Power Up	2 sec

Electrical Specifications

Table 2 – 240 V PT Models and Ratings

Model	Power (HP)	Output (kVA)	Max Steady State Output Current (AAC)	Input Voltage Range (VAC)	Max AC Input Current (A)	Standby Power/Energy, (W/BTU/hr)	Full Load Energy Loss (BTU/hr)
PT007	7.5	10.8	26	187-260	45	70/239	479
PT010	10	14.9	36		62	74/252	661
PT020	20	26.6	64		111	80/273	1180
PT030	30	39.4	95		165	175/597	1752
PT040	40	54.0	130		225	190/648	2395
PT050	50	68.5	165		286	235/802	3043
PT060	60	78.9	190		329	260/887	3500
PT075	75	99.7	240		416	300/1024	4427

Table 3 – 240 V PTE Models and Ratings

Model	Power (HP)	Output (kVA)	Max Steady State Output Current (AAC)	Input Voltage Range (VAC)	Max AC Input Current (A)	Standby Power/Energy, (W/BTU/hr)	Full Load Energy Loss (BTU/hr)
PTE007 PTE007QT	7.5	10.8	26	187-260	45	70/239	479
PTE010 PTE010QT	10	14.9	36		62	74/252	661
PTE015	15	21.6	52		90	77/263	958
PTE020	20	26.6	64		111	80/273	1180

Table 4 – Voltage Doubling PTE Models and Ratings

Model	Power (HP)	Output (kVA)	Max Steady State Output Current (AAC)	Input Voltage Range (VAC)	Max AC Input Current (A)	Standby Power/Energy (W/BTU/hr)	Full Load Energy Loss (BTU/hr)
PTE207QT	7.5	10.8	13	187-260	45	200/682	1938
PTE210QT	10	14.9	18		62	320/1092	2685
PTE215QT	15	22.4	27		94	435/1484	4029
PTE220QT	20	26.6	32		111	550/1876	4777

Table 5 – 480 V PT Models and Ratings

Model	Power (HP)	Output (kVA)	Max Steady State Output Current (AAC)	Input Voltage Range (VAC)	Max AC Input Current (A)	Standby Power/Energy, (W/BTU/hr)	Full Load Energy Loss (BTU/hr)
PT407	7.5	10.8	13	440-520	22	52/177	479
PT410	10	14.9	18		32	68/232	661
PT415	15	22.4	27		47	71/242	994
PT420	20	26.6	32		55	74/252	1180
PT430	30	38.2	46		80	87/297	1694
PT440	40	50.7	61		105	180/614	2249
PT450	50	64	77		134	190/648	2839
PT460	60	75.6	91		157	220/751	3358
PT475	75	88.9	107		185	270/921	3992
PT4100	100	118	142		246	300/1024	5239

Table 6 – 480 V PTE Models and Ratings

Model	Power (HP)	Output (kVA)	Max Steady State Output Current (AAC)	Input Voltage Range (VAC)	Max AC Input Current (A)	Standby Power/Energy, (W/BTU/hr)	Full Load Energy Loss (BTU/hr)
PTE407	7.5	10.8	13	440-520	22	52/177	479
PTE410	10	14.9	18		32	68/232	661
PTE415QT	15	22.4	27		48	71/242	994
PTE420QT	20	26.6	32		55	74/252	1180

Mechanical Specifications

Table 7 – 240 V PT Models – Enclosure Specifications

Models	PT007	PT010	PT020	PT030	PT040	PT050	PT060	PT075
Dimensions Indoor: NEMA 1 (H x W x D)*	36 15/16" x 25 3/8" x 17 1/16"			32 13/16" x 20 3/4" x 14 3/4"	36 1/4" x 27 13/16" x 15 3/4"	44 15/16" x 25 13/16" x 16 3/4"		
Dimensions Outdoor: NEMA 3R (H x W x D)*	37 7/16" x 25 3/8" x 19 5/16"			35 1/8" x 20 3/4" x 18 13/16"	38 7/8" x 27 13/16" x 19 5/16"	46 1/8" x 25 13/16" x 20 1/8"		
Weight (lbs)	102	104	129	222	233	251	255	288

Table 8 – 240 V PTE Models – Enclosure Specifications

Models	PTE007	PTE007QT	PTE010	PTE010QT	PTE015	PTE020
Dimensions Outdoor: NEMA 3R (H x W x D)*	25 1/16" x 22 5/8" x 7 15/16"	35 1/16" x 21 5/8" x 7 15/16"	25 1/16" x 22 5/8" x 7 15/16"	35 1/16" x 21 5/8" x 7 15/16"		
Weight (lbs)	51	60	51	65	71	72

Table 9 – Voltage Doubling PTE Models – Enclosure Specifications

Models	PTE207QT	PTE210QT	PTE215QT	PTE220QT
Dimensions Outdoor: NEMA 3R (H x W x D)*	35 1/16" x 21 5/8" x 7 15/16"			36" x 21 5/8" x 9"
Weight (lbs)	65	68	74	80

Table 10 – 480V PT Models - Enclosure Specifications

Models	PT407	PT410	PT415	PT420	PT430	PT440	PT450	PT460	PT475	PT4100
Indoor: NEMA 1 (HxWxD)	31 3/8" x 17 3/16" x 15 1/16"				36 15/16"x 25 3/8"x 17 1/16"	44 15/16" x 25 13/16" x 16 3/4"				
Outdoor: NEMA 3R (HxWxD)*	31 3/8" x 22 7/16" x 15 1/16"				37 7/16" x 25 3/8" x 19 5/16"	46 1/8" x 25 13/16" x 20 1/8"				
Weight (lbs)	70	74	80	80	141	242	246	256	268	305

Table 11 – 480V PTE Models - Enclosure Specifications

Models	PTE407	PTE410	PTE415QT	PTE420QT
Dimensions Outdoor: NEMA 3R (H x W x D)*	25 1/16" x 22 5/8" x 7 15/16"	25 1/16" x 22 5/8" x 7 15/16"	35 1/16" x 21 5/8" x 7 15/16"	
Weight (lbs)	56	56	70	72

**Note: Dimensions are maximum measurements including mounting hardware and optional MCCB handle, where applicable. Weights include MCCB*

Dimensional Drawings

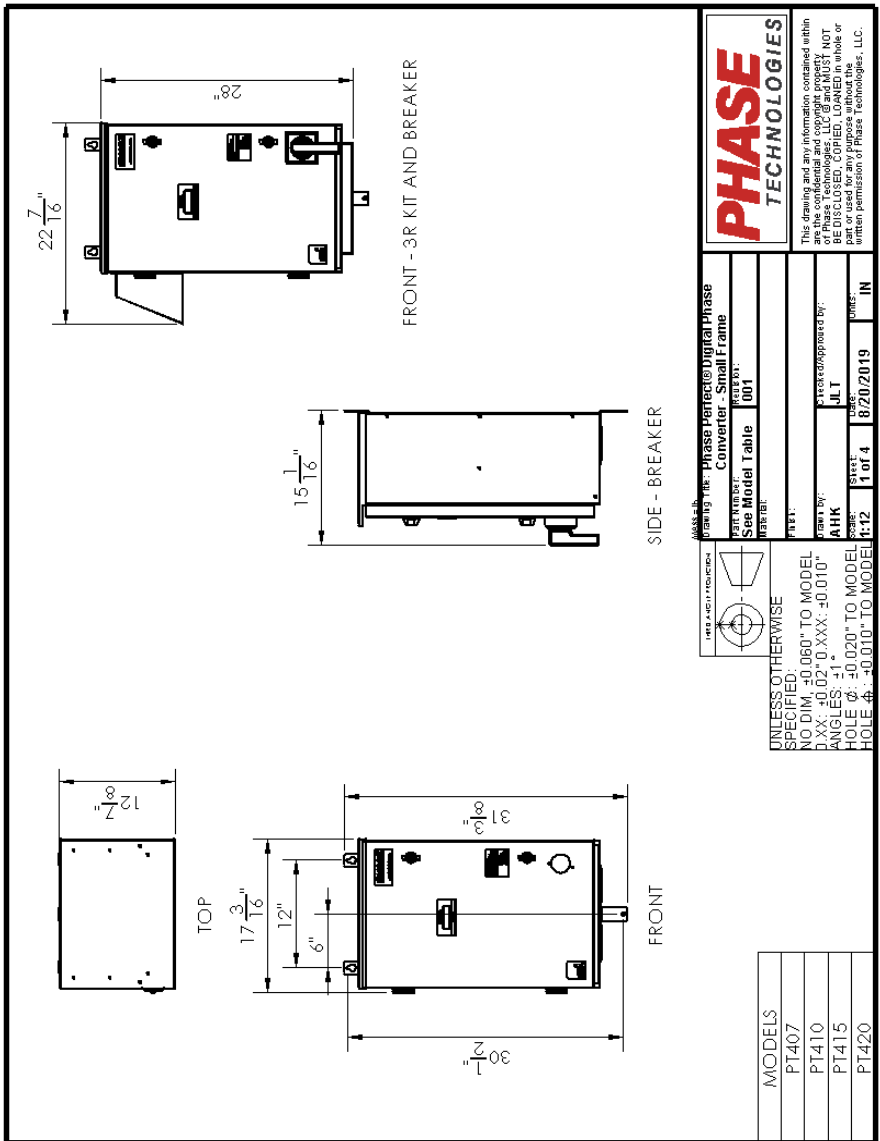


Figure 4 – PT Small Frame Dimensions

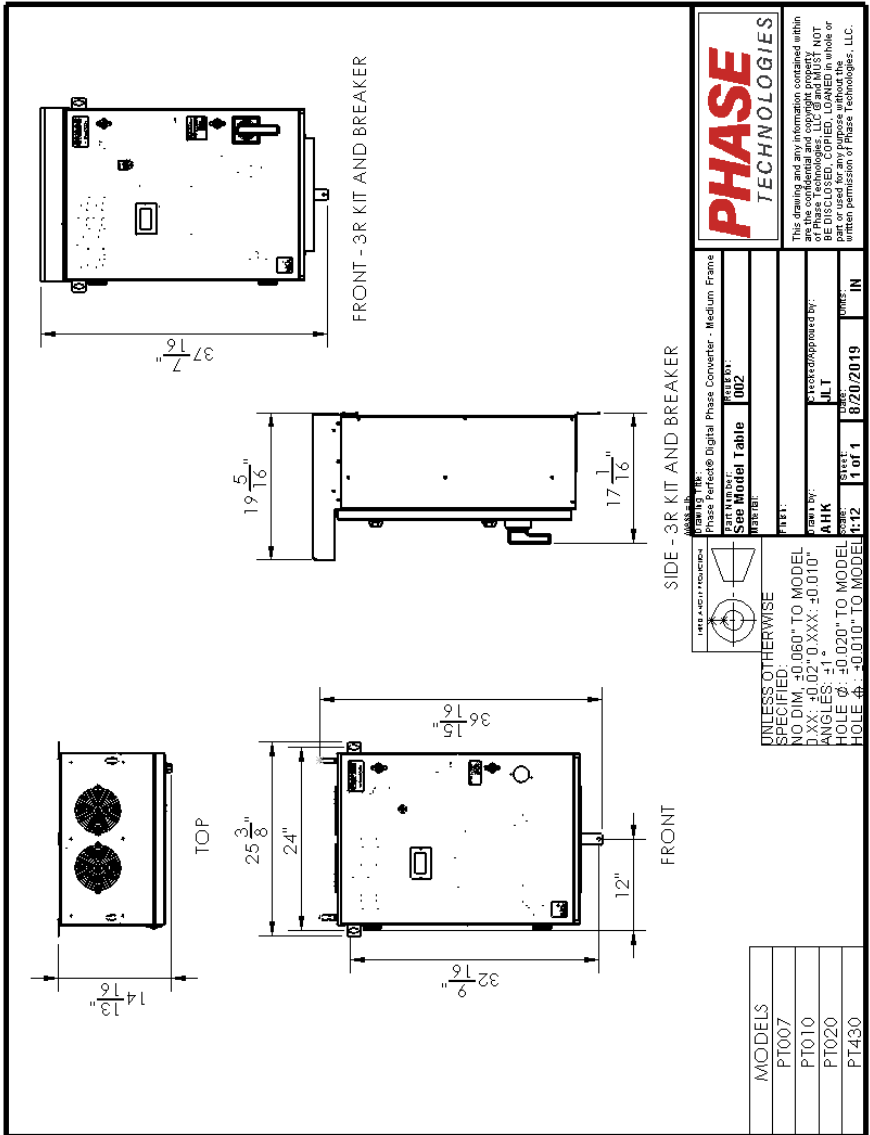


Figure 5 – PT Medium Frame Dimensions

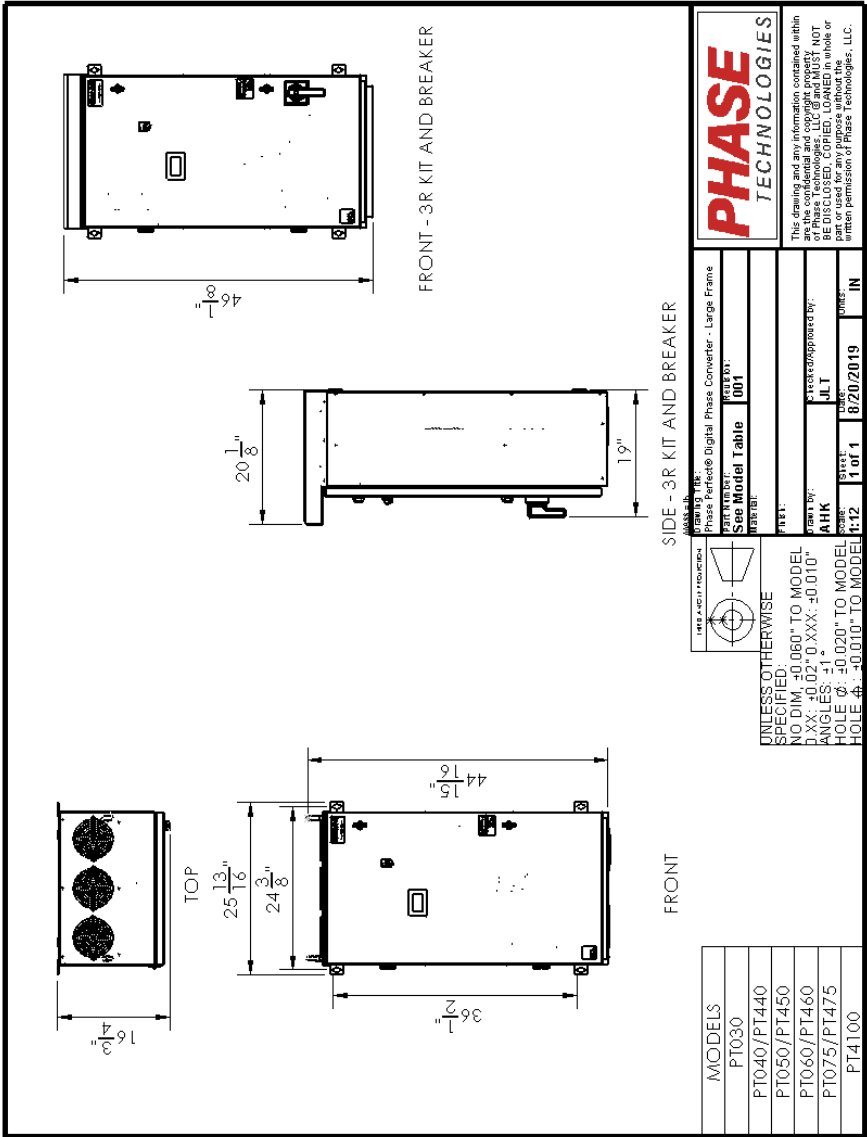


Figure 6 – PT Large Frame Dimensions

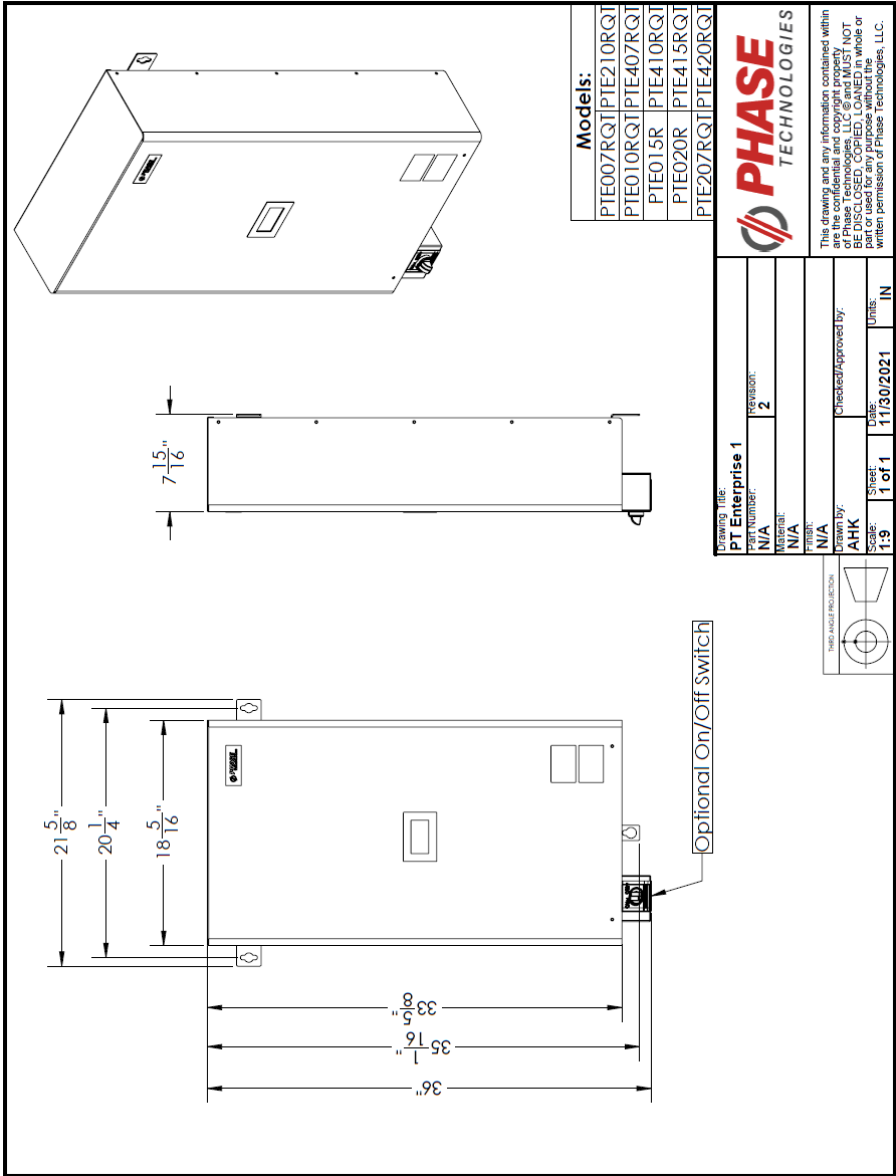

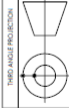


Figure 7 – PTE Frame 1

	
This drawing and any information contained within are the confidential and copyright property of PHASE TECHNOLOGIES, INC. IT IS NOT TO BE DISCLOSED, COPIED, LOANED in whole or part or used for any purpose without the written permission of Phase Technologies, LLC.	
Drawing Title: PTE Enterprise 1	Revision: 2
Drawing Number: N/A	Material: N/A
Material: N/A	Finish: N/A
Drawn by: AHK	Checked/Approved by:
Scale: 1:9	Date: 11/30/2021
Sheet: 1 of 1	Units: IN



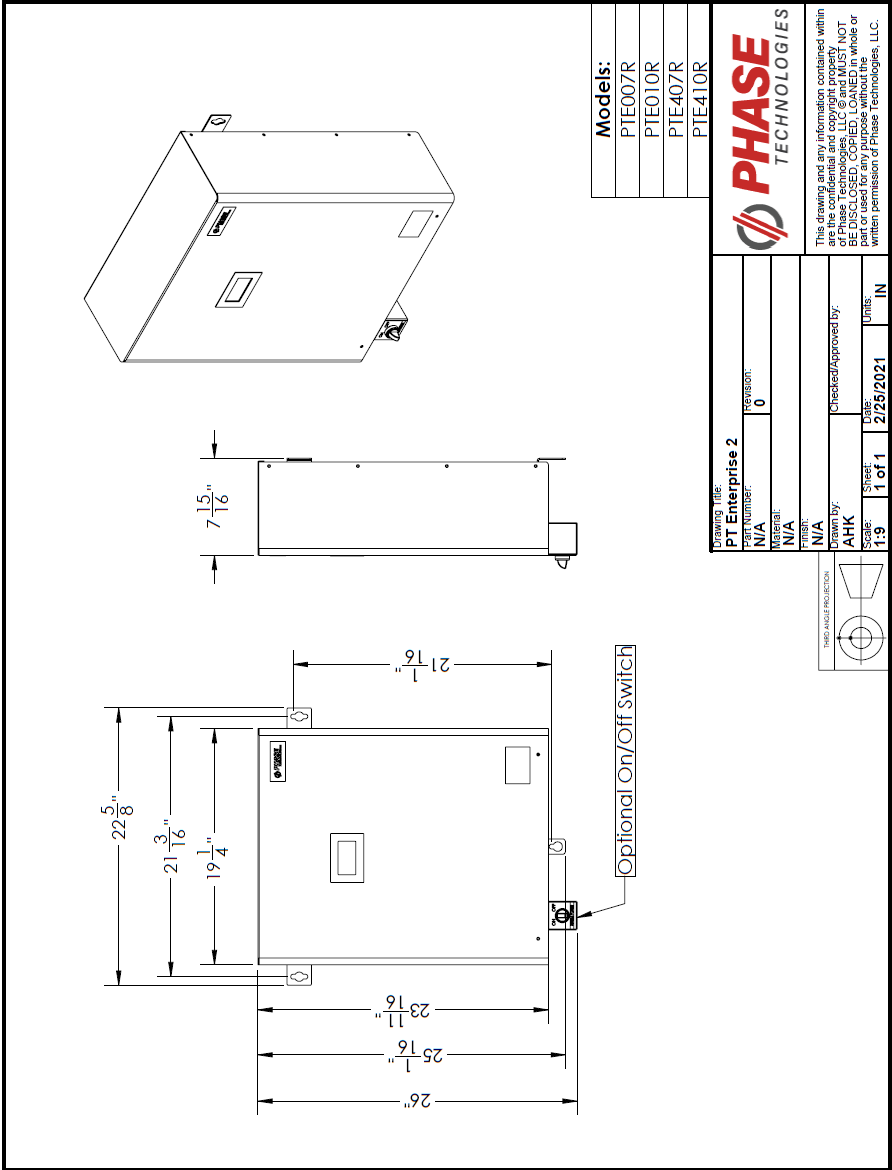


Figure 8 – PTE Frame 2

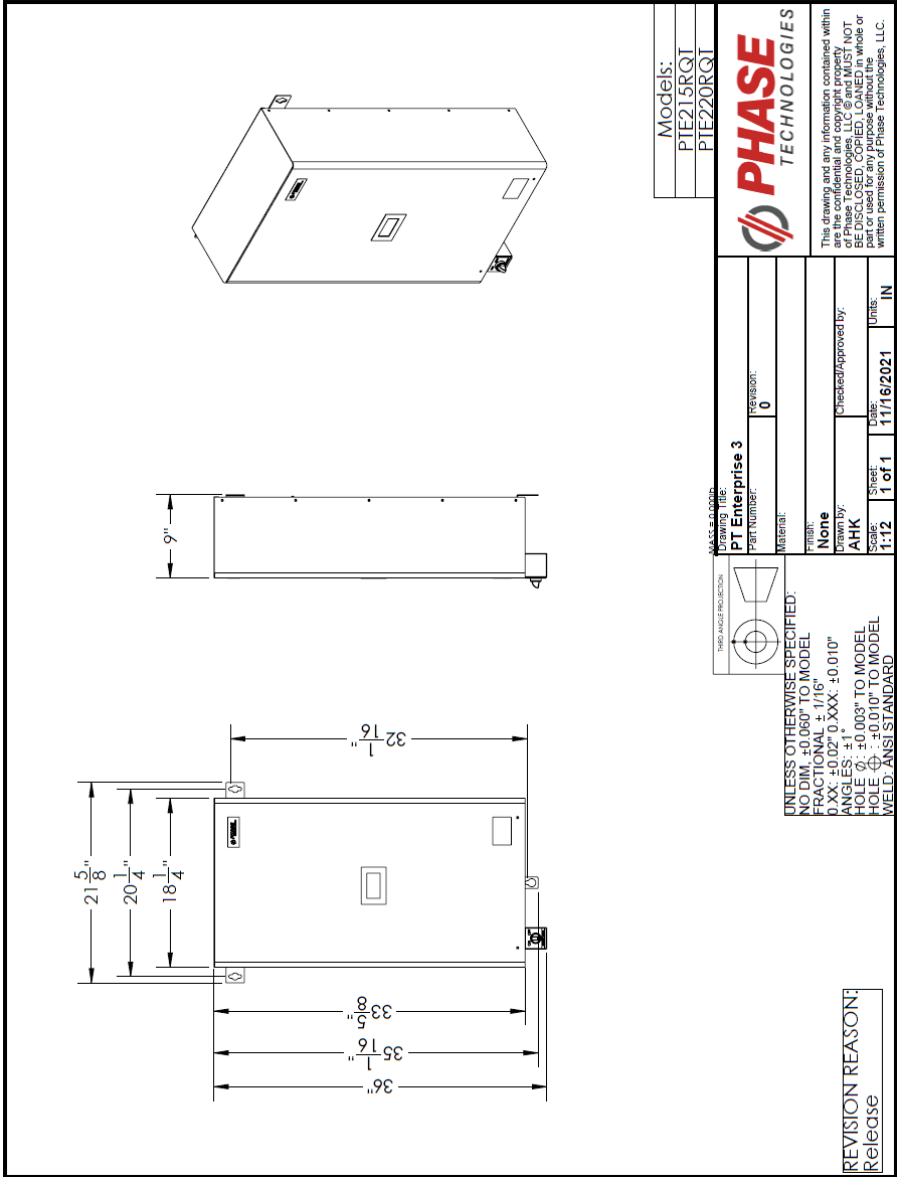


Figure 9 – PTE Frame 3

INSTALLATION

Mounting Your New Phase Perfect

Proper installation of the unit is important to the performance and normal operating life of the unit. The unit should be installed in a location free from:

- Corrosive gases or liquids
- Excessive vibration
- Airborne metallic particles

Mount the unit to a solid, non-flammable surface capable of bearing the weight using the mounting brackets provided with the unit. Model weights are found in **Table 7 – Table 11**.

Mounting Bracket Installation

For shipping purposes, mounting brackets may be installed upside down, or shipped separately in a bag. If the mounting brackets are not installed in an upright position, remove the mounting screws, turn to an upright position, and then fasten the screws tightly.

Proper Ventilation

To maintain air circulation for adequate cooling, minimum clearance around the unit must be maintained. Allow six inches on each side and top, and at least 18 inches below.

Ensure air intake and exhaust openings are not obstructed. If the unit is mounted in a small room, cabinet, or building, ensure there is adequate ventilation to provide sufficient cooling.

Service Entrance Equipment

Phase Perfect phase converters are suitable for use as service equipment when the molded case circuit breaker (MCCB)/disconnect, service ground conductor terminal, and grounding electrode conductor are factory installed and the converter is labeled "Suitable for use as Service Equipment." Consult local electrical code for installation guidance.

Source Branch Circuit Protection

If a circuit breaker is not factory installed, branch circuit protection must be installed in the circuit sourcing the phase converter. See **Table 12** for recommended circuit breaker sizing. Fuses may be used for circuit protection, consult local electrical code for proper sizing. Installation of a disconnection means within sight of the phase converter is recommended.

Grounding

- Properly ground the phase converter according to local electrical code.
- Connect the ground lug to the branch circuit or service ground conductor.
- Ground the phase converter with an adequately sized conductor according to local electrical code.
- Ground wire recommendations based on solid to semi-rigid stranded copper wire.

Table 12 – Ground Wire Specifications

Models	Recommended Circuit Breaker (A)	Wire Range (AWG)	
		Min	Max
PT007/PTE007	60	10	2
PT010/PTE010	80	8	2
PTE015	125	6	2
PT020/PTE020	150	6	2
PT030	225	4	2
PT040	300	4	2
PT050	400	3	2/0
PT060	500	2	2/0
PT075	600	1	2/0
PTE207	60	8	2
PTE210	80	6	2
PTE215	125	6	2
PTE220	150	6	2
PT407/PTE407	30	10	2
PT410/PTE410	40	10	2
PT415/PTE415	60	10	2
PT420/PTE420	70	8	2
PT430	100	8	2
PT440	150	6	2
PT450	175	6	2
PT460	200	6	2
PT475	250	4	2
PT4100	400	3	2/0

See terminal markings for additional wire size and torque information.

Connecting Source Power

Table 13 – Input Wiring

Wire size recommendations based on 600 VAC copper wire, rated either 60°C or 75°C. Assuming 86°F (30°C) ambient and no more than 3 current carrying conductors in raceway or earth (directly buried). If phase converter will be in warmer environments, consult NEC Handbook for temperature correction factor.

Input Wiring Recommendations		
	Min. Wire Gauge (60°C)	Min. Wire Gauge (75°C)
PT007/PTE007	4 AWG	6 AWG
PT010/PTE010	3 AWG	4 AWG
PTE015	1/0 AWG	1 AWG
PT020/PTE020	-	1/0 AWG
PT030	300 kcmil	4/0 AWG
PT040	-	350 kcmil
PT050	2 x 250 kcmil	2 x 3/0 AWG
PT060	2 x 300 kcmil	2 x 250 kcmil
PT075	2 x 500 kcmil	2 x 350 kcmil
PTE207	4 AWG	6 AWG
PTE210	3 AWG	4 AWG
PTE215	1/0 AWG	1 AWG
PTE220	-	1/0 AWG
PT407/PTE407	10 AWG	10 AWG
PT410/PTE410	8 AWG	8 AWG
PT415/PTE415	4 AWG	6 AWG
PT420/PTE420	4 AWG	4 AWG
PT430	1 AWG	3 AWG
PT440	-	1/0 AWG
PT450	-	2/0 AWG
PT460	250 kcmil	3/0 AWG
PT475	350 kcmil	250 kcmil
PT4100	2 x 250 kcmil	2 x 3/0 AWG

Wire Sizing

Use **Table 13** to find minimum guidelines on properly sizing input conductors according to local electrical code. The voltage drop from the supply to the converter should be limited to 3% to ensure proper starting and operation of motor loads. Increase the wire gauge to provide adequate voltage to the load. Ensure the wire gauge is suitable to the terminal block.

Use the following formula to calculate line voltage drop.

$$V_{drop} = \text{wire resistance} \left(\frac{\Omega}{ft} \right) \times \text{wire length (ft)} \times \text{current}$$

Connecting the Load

Do not connect single-phase loads to the manufactured leg, T3. This places unnecessary load on the phase converter and may violate electrical code in some areas. Apply overload and short circuit protection to protect load side conductors, motors, and other attached loads according to local electrical code. For some motor loads and wiring configurations load side short circuit protection may not be required. Consult local electrical code for guidance.

Important Note:

If the connected load requires a wye configured power source with a neutral connection, the load must be connected to the phase converter using a delta-wye isolation transformer.

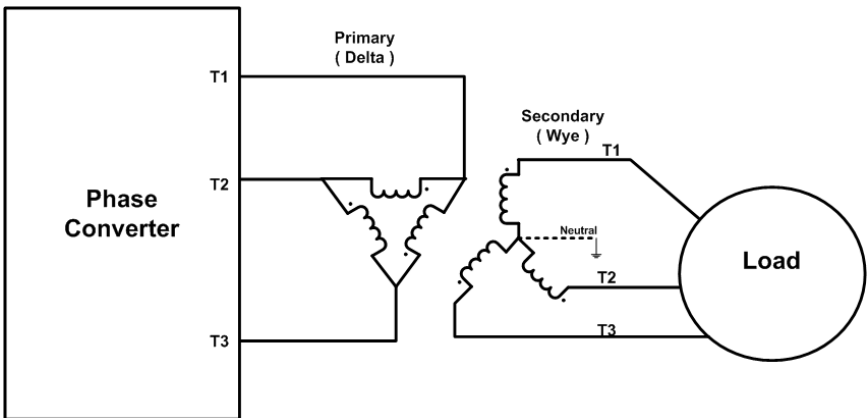


Figure 10 – Delta Wye Wiring Diagram

Table 14 – Input Power Terminal Specifications - PT

Input Power Terminals: Allowed Wire Range & Minimum Torque					
Model					
PT007, PT010, PT020, PT407, PT410, PT415, PT420, PT430, PT440, PT450		PT030, PT040, PT460, PT475		PT050, PT060, PT075, PT4100	
Wire Size	Torque	Wire Size	Torque	Wire Size	Torque
2/0 – 6 AWG	120 in-lb	350 kcmil- 6 AWG	275 in-lb	2x500 kcmil- 2x4 AWG	375 in-lb
8 AWG	40 in-lb				
10 – 14 AWG	35 in-lb				

Table 15 – Input Power Terminal Specifications - PTE

Input Power Terminals: Allowed Wire Range & Minimum Torque			
Model			
PTE007, PTE007QT, PTE010, PTE010QT, PTE207QT, PTE210QT, PTE215QT, PTE220QT, PTE407, PTE410, PTE415QT, PTE420QT			PTE015, PTE020
Wire Size	Torque	Wire Size	Torque
2 – 20 AWG	17.5 in-lb	2/0 – 6 AWG 8 AWG 10 – 14 AWG	120 in-lb 40 in-lb 35 in-lb

Table 16 – Output Power Terminal Specifications

Output Power Terminals: Allowed Wire Range & Minimum Torque			
Model			
PT007, PT010, PT020, PT030, PT040, PT407, PT410, PT415, PT420, PT430, PT440, PT450, PT460, PT475		PT050, PT060, PT075, PT4100	
Wire Size	Torque	Wire Size	Torque
2/0 – 6 AWG	120 in-lb	350 kcmil – 6 AWG	275 in-lb
8 AWG	40 in-lb		
10 – 14 AWG	35 in-lb		

Table 17 – Output Power Terminal Specifications - PTE

Output Power Terminals: Allowed Wire Range & Minimum Torque	
Model	
PTE007, PTE007QT, PTE010, PTE010QT, PTE015, PTE020, PTE207QT, PTE210QT, PTE215QT, PTE220QT, PTE407, PTE407QT PTE410, PTE415QT, PTE420QT	
Wire Size	Torque
4 – 18 AWG	16 in-lbs

Table 18 – Field Wiring Tools

Model	Line Side	Load Side
PT007	3/16" Hex	3/16" Hex
PT010		
PT020		
PT030		
PT040	5/16" Hex	5/16" Hex
PT050		
PT060		
PT075		

Model	Line Side	Load Side
PT407	3/16" Hex	3/16" Hex
PT410		
PT415		
PT420		
PT430		
PT440		
PT450		
PT460	5/16" Hex	
PT475		
PT4100		

Model	Line Side	Load Side
PTE007	Phillips Screwdriver	Flathead Screwdriver
PTE007QT		
PTE010		
PTE010QT		
PTE015	3/16" Hex	
PTE020	Phillips Screwdriver	
PTE207QT		
PTE210QT		
PTE215QT	3/16" Hex	
PTE220QT		

Model	Line Side	Load Side
PTE407	Phillips Screwdriver	Flathead Screwdriver
PTE407QT		
PTE410		
PTE410QT		
PTE415QT		
PTE420QT		
PTE420QT		

Table 19 – Optional Circuit Breaker Wire Size and Torque

Models	Circuit Breaker Family	Min	Max	Min Torque (in-lb)	Wire Strip
PT007 PT010 PT407 PT410 PT415 PT420 PT430	LS UTE100	14	10	31.9	0.7"
		8		39.9	
		6	3	47.8	
		2	1	55.7	
		14		36.2	
PT020 PT440	LS UTS150	12	10	47.8	1.01"
		8	2/0	133.6	
		14		36.2	
PT030 PT450 PT460 PT475	LS UTS250	1/0	2/0	254.9	1.27"
		3/0	4/0	350.5	
		250 kcmil	300 kcmil	350.5	
		14		36.2	
PT040 PT050 PT4100	LS UTS400	1/0	300 kcmil	358.4	1.76"
		350 kcmil	600 kcmil	477.9	
		14		36.2	

Connecting to Field Wiring Terminals

Open the front door of the enclosure to gain access to the wiring panel. See **Figure 11 - Figure 15**.

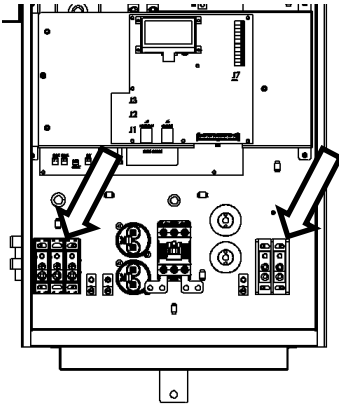


Figure 11 – PT Small Frame Field Wiring Terminals

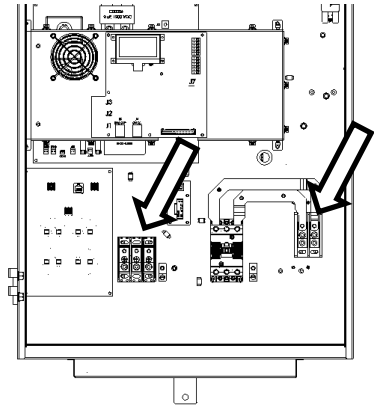


Figure 12 – PT Medium Frame Field Wiring Terminals

Small Frame Models:
PT407, PT410, PT415,
PT420

Medium Frame Models:
PT007, PT010, PT020,
PT430

Large Frame Models:
PT030, PT040, PT050,
PT060, PT075, PT440,
PT450, PT460, PT475,
PT4100

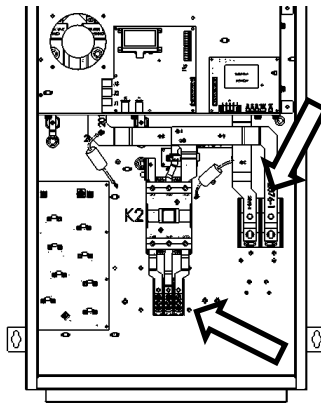


Figure 13 – PT Large Frame Field Wiring Terminals

Table 20 – Power Terminal Descriptions

Terminal Name	Description
L1, L2	Single phase input power terminals
T1, T2, T3	3 Phase output power terminals, T3 is the “manufactured” leg.
GND	Earth ground

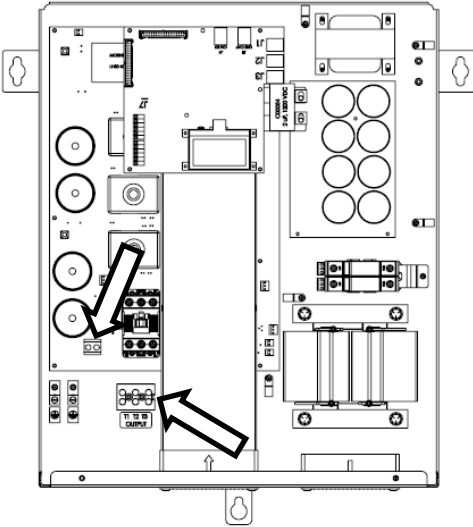


Figure 14 – PTE Field Wiring Terminals: PTE007, PTE007QT, PTE010, PTE010QT, PTE207, PTE407, PTE407QT, PTE410, PTE415QT, PTE420QT

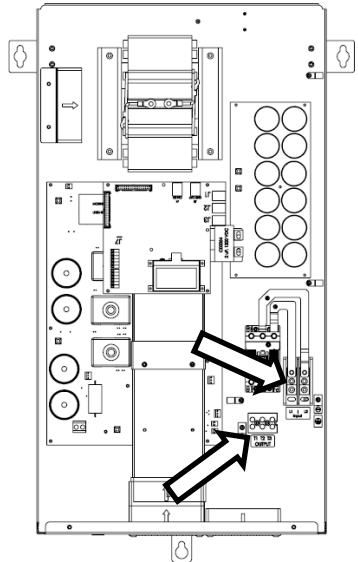


Figure 15 – PTE Field Wiring Terminals: PTE015, PTE020, PTE210, PTE215, PTE220

Routing Power Cables

Note: Continuous metal conduit should be used for all power cables to reduce radiated electromagnetic interference (EMI). The conduit must be securely grounded to the converter enclosure and the motor case. Conduit hubs should be IMC or rigid steel conduit and be UL listed. Conduit hub locations can be seen in **Figure 16 - Figure 20**.

Route power cables through the supplied openings in the bottom of the enclosure, using appropriate conduit or strain relief devices. Unused conduit holes must be covered with a conduit hole plug.

Important Note: If new openings are cut, be sure to completely remove all resulting metal shavings.

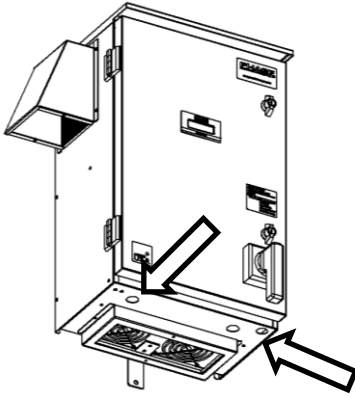


Figure 16 – PT Small Frame Conduit Locations

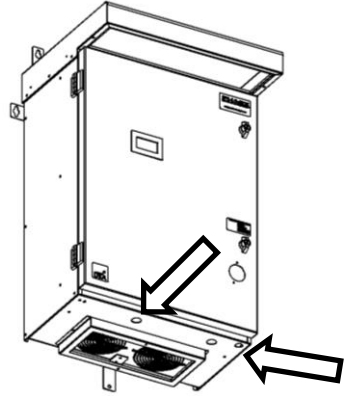


Figure 17 – PT Medium Frame Conduit Locations

Small Frame Models:
PT407, PT410, PT415,
PT420

Medium Frame Models:
PT007, PT010, PT020,
PT430

Large Frame Models:
PT030, PT040, PT050,
PT060, PT075, PT440,
PT450, PT460, PT475,
PT4100

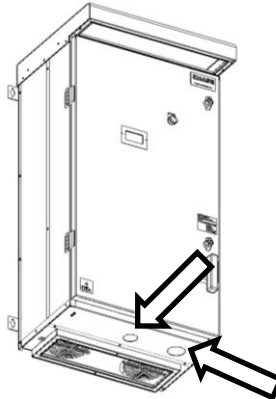


Figure 18 – PT Large Frame Conduit Locations

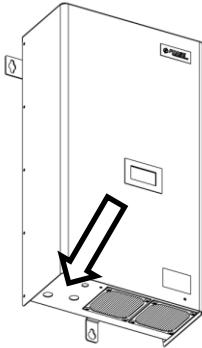


Figure 19 – PTE Conduit Locations:
 PTE007, PTE007QT, PTE010, PTE010QT,
 PTE407, PTE407QT, PTE410, PTE415QT,
 PTE420QT

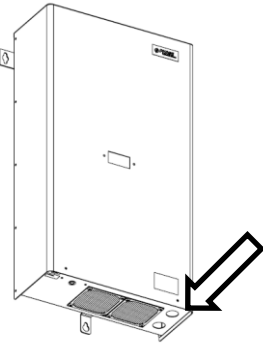


Figure 20 – PTE Conduit Locations:
 PTE015, PTE020, PTE207QT, PTE210QT,
 PTE215QT, PTE220QT

ON/OFF Control Wiring

The output of the converter can be controlled with a switch connected between the AUX1 or AUX2 and COM terminals. If installed, remove the factory installed jumper wire and replace with a switch. Jumper wire can be seen in **Figure 21** below.

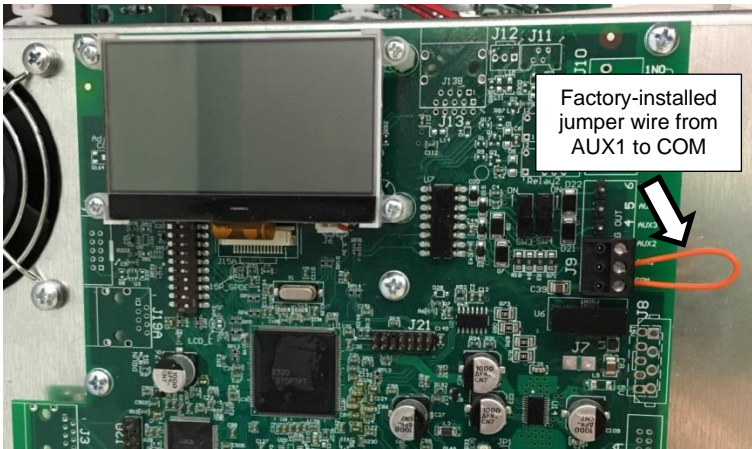


Figure 21 – Control Terminal Locations

When AUX1 to COM or AUX2 to COM is closed, the output is energized after a delay of approximately two seconds. When AUX1 and AUX2 to COM are open, the output of the converter will be de-energized. The diagram in **Figure 22** illustrates the UL508A panel shop and customer installed options including an ON/OFF control switch. Unused conduit holes must be filled with a conduit hole plug.

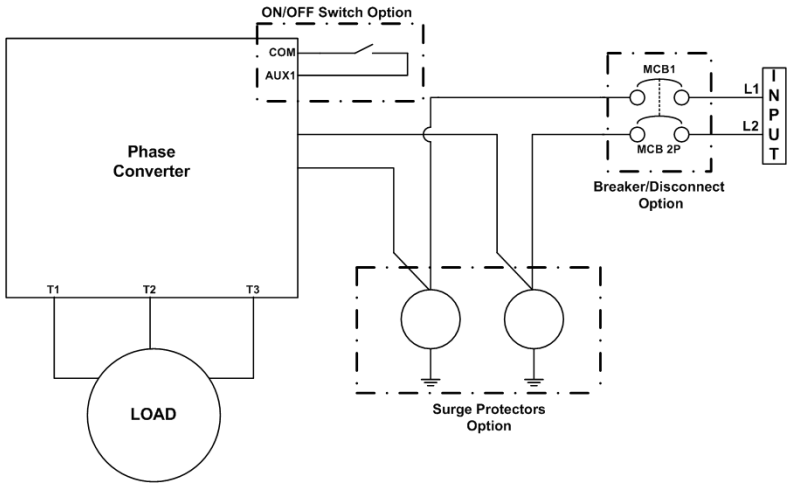


Figure 22 – Panel Shop Options



WARNING! When the converter is turned OFF using a switch on the AUX terminals, dangerous voltage may still be present on the input lines and elsewhere inside the enclosure. **Never open the enclosure or perform maintenance on the unit or connected loads when the incoming power to the phase converter is ON, regardless of the switch setting.**

Table 21 – Control Terminal Ratings and Descriptions

Terminal	Description	Rating	Comments
AUX1	Auxiliary Input 1	Dry contact type Pullup Voltage < 5 volts, galvanically isolated	Digital input. Commonly used for ON/OFF control of output.
AUX2	Auxiliary Input 2		Common for AUX terminals.
COM	Common		RESERVED - DO NOT USE
AUX3	Auxiliary Input 3		
AUX4	Auxiliary Input 4		



CAUTION! Electrostatic discharge (ESD) can damage electronic components. Discharge ESD prior to touching the board or making connections. To discharge ESD, touch your hand to unpainted metal on the enclosure.

OPERATION

LCD Status Screen

When the unit is powered up, the screen will scroll through the operating parameters.



Figure 23 – Status Screen



Figure 24 – “System Off” Status Screen

DIP Switch Settings

⚠ WARNING! Make sure the input power disconnect switch is in the OFF position before opening the front cover to the unit. Opening the front cover with the switch in the ON position exposes the user to the risk of electric shock.

⚠ WARNING: Risk of electric shock. Disconnect all incoming sources of power and wait 30 minutes before opening the front cover to change the DIP switch.

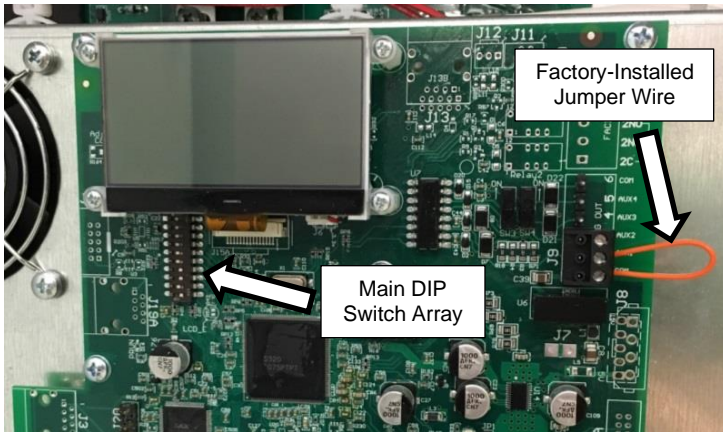


Figure 25 – Location of DIP Switches and Slide Switches

Table 22 – DIP Switch Settings

DIP Switch	Function	Default
9 & 10	Bypass AUX1 & AUX2 both ON	OFF/OFF
10	Enable VFD Mode note: SW9 must be OFF	OFF

Bypass AUX Inputs

When both DIP switches 9 and 10 are in the **ON** position, AUX1 and AUX2 inputs will be bypassed causing the output to energize regardless of the state of AUX1 and AUX2.

Enable VFD Mode

In VFD mode the phase converter will automatically adjust the current on the generated leg to balance the three-phase currents by adjusting the voltage of the generated leg. In this mode, the output voltage may not be balanced. This function is typically used to prevent overheating of the VFD due to unbalanced currents induced by the non-linear nature of the VFD inverter. Turn power to the unit off and set DIP switch 10 to the **ON** position to enable VFD mode.

Voltage Calibration

⚠ WARNING! Risk of electric shock. De-energize the unit by disconnecting all incoming sources of power, then wait 30 minutes for internal charges to dissipate before servicing the equipment.

Calibrating voltage will require wiring two ON/OFF switches to the converter. Standard light switches will work. See **Figure 26** below, for wiring diagram.

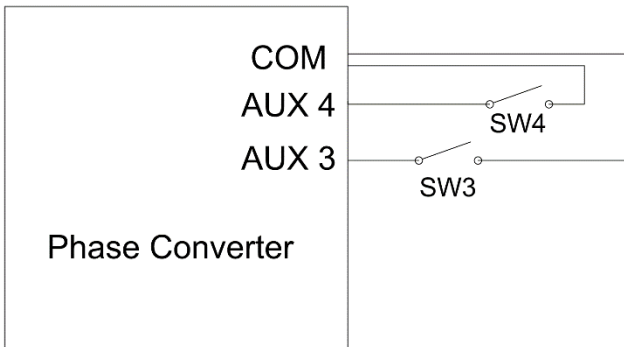


Figure 26 – Wiring Diagram for SW3 and SW4

To adjust output voltage, follow the steps below:


Step	Action
1	Turn power to PT OFF
2	Remove jumper wire between AUX1 and COM
3	Wire dry contact switch between AUX3 and COM (now called SW3)
4	Wire dry contact switch between AUX4 and COM (now called SW4)
5	Turn power to the PT ON
6	SW4: ON
7	SW3: ON

Toggle SW4 to move between **ADJUST V23** and **ADJUST V31**. When the desired parameter is shown on the display, toggle SW3 **OFF** then **ON** to enter selected menu.

Action	Effect
Toggle SW3	Decrease selected voltage
Toggle SW4	Increase selected voltage

When adjusting output voltage, make changes in small increments (5 V or less) to begin, then let the menu time out to save the change. After **“Programmed Successfully”** is shown on the display, return switches to the **OFF** position. Turn power to converter **OFF**, re-install jumper wire between **AUX1** and **COM**, then reapply power to converter and measure voltages to verify change in calibration. Repeat this procedure, using smaller increments as you get close, until desired output voltage is reached. When voltage calibration has been completed, turn power to the PT **OFF**. Remove SW3 and SW4, re-install the jumper wire connecting AUX1 and COM and re-apply power to converter.

Transformer Mode

 **WARNING!** Risk of electric shock. De-energize the unit by disconnecting all incoming sources of power, then wait 30 minutes for internal charges to dissipate before servicing the equipment.

Transformer Mode will allow T3 to drop in voltage during heavy startups. This will require wiring two ON/OFF switches to the converter. Standard light switches will work. See **Figure 26**, for wiring diagram.

To enable **Transformer Mode**, follow the steps below:


Step	Action
1	Turn power to PT OFF
2	Remove jumper wire between AUX1 and COM
3	Wire dry contact switch between AUX3 and COM (now called SW3)
4	Wire dry contact switch between AUX4 and COM (now called SW4)
5	Turn power to the PT ON
6	Toggle SW4 until you see TRANSFORMER 2/5 on display
7	SW3: ON, OFF, ON


Switches now act as toggles to make selection.

Action	Effect
SW4: ON, OFF	YES (enable transformer mode)
SW3: OFF	NO (disable transformer mode)

Leave Transformer select menu at desired setting, after 3 seconds of no switch toggling, the setting will be saved. **Switches must be returned to the OFF position after changes are complete.** Turn power to the PT **OFF** again. Remove SW3 and SW4, re-install the jumper wire connecting AUX1 and COM, and re-apply power to converter.

Elevator Mode

 **WARNING!** Risk of electric shock. De-energize the unit by disconnecting all incoming sources of power, then wait 30 minutes for internal charges to dissipate before servicing the equipment.

 **WARNING!** Using **Elevator Mode** on any application except an elevator will void manufacturer's warranty. **Transformer Mode** and **VFD Mode** can be used on any application without voiding warranty.

Elevator Mode forces T3 to maintain voltage during heavy startups. This setting should only be used if elevator is tripping due to a drop in input voltage. This will require wiring two ON/OFF switches to the converter. Standard light switches will work. See **Figure 26** for wiring diagram. To enable **Elevator Mode**, follow the steps below:


Step	Action
1	Turn power to PT OFF
2	Remove jumper wire between AUX1 and COM
3	Wire dry contact switch between AUX3 and COM (now called SW3)
4	Wire dry contact switch between AUX4 and COM (now called SW4)
5	Turn power to the PT ON
6	SW4: ON, OFF
7	SW3: ON, OFF, ON, OFF

Switches now act as toggles to make selection.

Action	Effect
SW4: ON, OFF	YES (enable elevator mode)
SW3: OFF	NO (disable elevator mode)

Leave Elevator select menu at desired setting, after 3 seconds of no switch toggling, the setting will be saved. **Switches must be returned to the OFF position after changes are complete.** Turn power to the PT **OFF** again. Remove SW3 and SW4, re-install the jumper wire connecting AUX1 and COM and re-apply power to converter.

Startup Delay

 **WARNING!** Risk of electric shock. De-energize the unit by disconnecting all incoming sources of power, then wait 30 minutes for internal charges to dissipate before servicing the equipment.

Startup Delay will force the converter to wait for a set time period before starting up. This procedure will require wiring two ON/OFF switches to the converter. Standard light switches will work. See **Figure 26** for wiring diagram. To add a startup delay, follow the steps below:


Step	Action
1	Turn power to PT OFF
2	Remove jumper wire between AUX1 and COM
3	Wire dry contact switch between AUX3 and COM (now called SW3)
4	Wire dry contact switch between AUX4 and COM (now called SW4)
5	Turn power to the PT ON
6	Toggle SW4 until you see STARTUP DLY 4/5 on screen
7	Toggle SW3 to select between YES or NO
8	Wait several seconds to allow this programming to be saved
9	Repeat steps 6 and 7
10	SW3 ON to access STARTUP DLY
11	SW4 ON to access DLY TIME

Switches now act as toggle to select the **STARTUP DELAY TIME**.

Action	Effect
Toggle SW3	Decrease delay time
Toggle SW4	Increase delay time

Wait several seconds until "**Programmed Successfully**" is shown on the display, and then return switches to the **OFF** position. Turn power to converter **OFF**, re-install jumper wire between **AUX1** and **COM**, then reapply power to converter.

Infinite Restarts

 **WARNING!** Risk of electric shock. De-energize the unit by disconnecting all incoming sources of power, then wait 30 minutes for internal charges to dissipate before servicing the equipment.

Infinite Restarts will allow the converter to restart an unlimited number of times after fault conditions. This procedure will require wiring two ON/OFF switches to the converter. Standard light switches will work. See **Figure 26** for wiring diagram. To add a startup delay, follow the steps below:

Step	Action
1	Turn power to PT OFF
2	Remove jumper wire between AUX1 and COM
3	Wire dry contact switch between AUX3 and COM (now called SW3)
4	Wire dry contact switch between AUX4 and COM (now called SW4)
5	Turn power to the PT ON
6	Toggle SW4 until you see INFINITE RESTARTS on screen
7	Toggle SW3 to select between YES or NO

Wait several seconds until "**Programmed Successfully**" is shown on the display, and then return switches to the **OFF** position. Turn power to converter **OFF**, re-install jumper wire between **AUX1** and **COM**, then reapply power to converter.

Fault Codes

Table 23 – Fault Codes

Text	Description/Comments	Restart
BUS OVERVOLTAGE	Sudden and severe regenerative power under high line voltage may result in bus overvoltage.	Auto
CLASS 4 OVERLOAD	Output current exceeded operating limit.	Auto
CM BOARD FAULT	Connection from Control board to Hall Sensor isn't properly connected. Power down unit, reconnect, and restart.	Manual
HALL SENSE HIGH	Current exceeded the maximum rating of the Hall sensor. May indicate a fault in the motor circuit.	Auto
HIGH INPUT VOLT	Input voltage has exceeded a safe operating level. Reduce input voltage.	Auto
IGBT FAULT	Check for short circuit on input and output lines and load. Contact Phase Technologies.	Manual
INPUT OVERLOAD	Input current exceeded the operating limit.	Auto
LINE CAP FAIL	Replace line capacitors or contact Phase Technologies for replacement.	Manual
LOW INPUT VOLT	Input voltage has fallen below a safe operating level.	Auto
OUTPUT OVERLOAD	A large and sudden overcurrent event on the output module. Check motor circuit for faults.	Auto
OVER TEMPERATURE	Internal temperature of the converter exceeded safe operating limits. Check fans and ventilation openings for obstruction. Reduce ambient temperature.	Auto
PLL FAULT	Phase-Locked Loop occurs when input frequency is ± 7 Hz of 60 Hz. Check input frequency.	Auto
PRECHARGE FAIL	Pre-charge circuit has failed to charge bus capacitors.	Manual
STIR FAN FAIL	PT420 and PTE420QT only. Temperature sensor near inductor has exceed safe operating limits. Wait for temperature to drop to safe level.	Auto
TEMP SENSE FAULT	Temperature sensor on the heat sink has failed or its cable is disconnected.	Manual
UNBALANCE BUS VOL	Potential damage to a bus capacitor or degradation of the bus balancing resistor.	Auto
VOLTAGE UNBALANCE	Output voltage difference between pass-through legs and generated leg is greater than 50 V.	Manual

Faults: Manual Restart

These faults generally indicate damage to the converter and/or the load. They may also indicate a potentially dangerous condition. When this type of fault occurs, the display will indicate the fault message and the converter output will remain off.



CAUTION! Contact Phase Technologies for assistance before restarting or troubleshoot the system thoroughly before power cycling the converter.



WARNING! Risk of electric shock. De-energize the unit by disconnecting all incoming sources of power, then wait 30 minutes for internal charges to dissipate before servicing the equipment.

Fault Log

The Fault Log records faults with number of occurrences. To access the Fault Log, wire a dry contact switch between AUX3 and COM (now called SW3), and wire a dry contact switch between AUX4 and COM (now called SW4). Standard light switches will work. Next, set SW3 and SW4 per **Table 24**. There are two fault logs – Master and User Fault Log.

Master Fault Log:

A non-resettable count of all faults over the life of the main circuit board

User Fault Log:

A resettable count of faults. Each fault type is limited to a count of 10. On the 11th fault, the unit will display the appropriate fault and the LCD screen will display "RESET? PWR CYCLE".

Power cycling the unit will reset the fault back to zero.

Table 24 – Modes for SW3 and SW4 (ON = up, OFF = down)

SW3	SW4	Result
OFF	OFF	Factory default: LCD screen will scroll various operating parameters – UNIT WILL OPERATE WHILE IN THIS MODE
ON	OFF	LCD screen will show Master Fault Log (non-resettable count of all faults) UNIT WILL NOT OPERATE WHILE IN THIS MODE
ON	ON	LCD screen will show User Fault Log (resettable count of all faults) UNIT WILL NOT OPERATE WHILE IN THIS MODE
OFF	ON	Reserved

TROUBLESHOOTING TIPS

If a fault occurs, a fault code will be displayed on the LCD screen. See **Table 23** for a list of fault codes. Fault codes generally indicate that an issue exists independent of the phase converter.

Table 25 – Troubleshooting

Problem	Potential Cause	Solution
No power	Incoming circuit breaker continually trips	IGBT troubleshooting
	Blown fuses	See page 36 for information on replacing fuses. If fuses are blown, this may also require replacing filter capacitors and/or the power board if the MOV's are damaged.
Load not operating	Fault code displayed	Use Table 23 for more information and guidance on fault codes. Clear the fault by power cycling the converter. Remove the load to determine if the issue is internal or external to the unit.
	AUX1 and AUX2 open	Check the jumper or switches connected to the AUX1 and/or AUX2 inputs
	Signals to the Control Terminals corrupted	Shielded cable is required for AUX terminal leads longer than 20 ft.
	Input terminals L1 and L2 not energized	Check the main input fuses or breaker. Check the secondary circuit fuses. See Figure 34 - Figure 36 .
	Overcurrent fault in elevator application	Check elevator specs to ensure PT is sized correctly.
Motor is spinning backwards	Phase sequence to motor is wrong.	Swap any two of the three motor leads.
LED lights flickering or other electrical noise issues	Electromagnetic interference issues	Ensure that problem does not persist when PT is powered off. Check and improve grounding. LED lighting can be prone to noise/flickering when all LED lights are being used. Installing an incandescent light in a given circuit can often resolve these problems. Consider installing an EMI filter on the phase converter input.

ROUTINE INSPECTION AND MAINTENANCE



HIGH VOLTAGE: This equipment is connected to line voltages that can create a potentially hazardous situation. Electric shock could result in serious injury or death. This device should only be installed and serviced by trained and licensed personnel. Follow instructions carefully and observe all warnings.



WARNING! Under certain operating conditions, the converter will shut down and automatically restart. Always disconnect input power from the unit and wait 30 minutes for charge to dissipate before performing service on the converter or connected loads.

Overall: Perform visual inspection, checking for things such as discolored wires or terminals, evidence of arcing, loose mounting screws, physical damage to the enclosure, etc. The converter should be inspected and cleaned annually or more frequently if located in a hot or dirty environment. Special attention should be given to the following:

Power terminals: Periodically, inspect for loose connections and tighten to specifications in **Table 14 – Table 17**.

Capacitors: Check for leakage or deformation.

Fans and heatsinks: Excessive dust buildup on heatsink or fan impellers may lead to overheating. Lightly brush and vacuum. Contact Customer Service for assistance in replacing cooling fans. Use only fans approved by Phase Technologies. Unapproved fans may lead to component damage.

Line Filter Capacitors

Line filter capacitors are part of the inductor/capacitor (L/C) filters and should be routinely monitored and replaced if degraded. Failure of the L/C filter can lead to increased harmonic levels, which may damage equipment connected to converter. **Figure 27 - Figure 29** to identify the line filter capacitors.

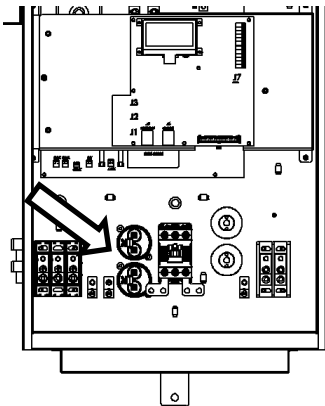


Figure 27 – PT Small Frame Line Filter Capacitors

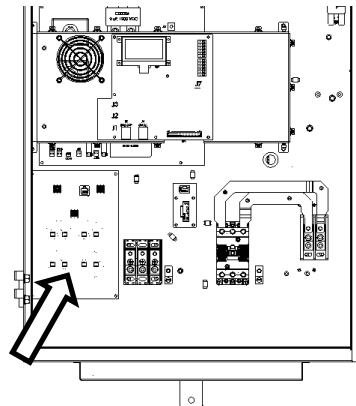


Figure 28 – PT Medium Frame Line Filter Capacitors

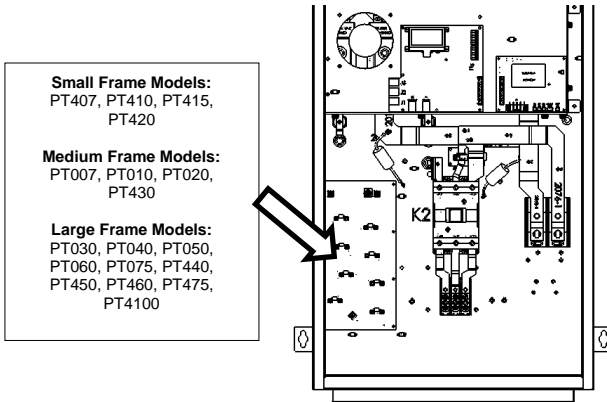


Figure 29 – PT Large Frame Line Filter Capacitors

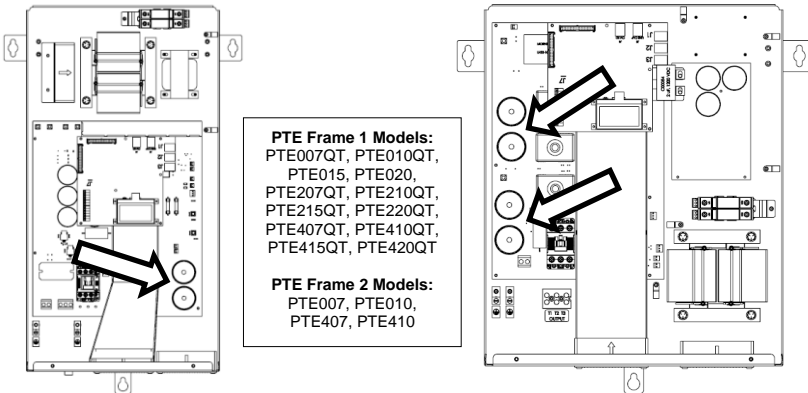


Figure 30 – PTE Frame 1 Line Filter Capacitors

Figure 31 – PTE Frame 2 Line Filter Capacitors

Visually inspect the line filter capacitors and connecting wires for any discoloration or bulges in the canisters.

For **PT Small Frames**, disconnect the wires from the capacitor being measured, noting where they were connected. Use a multi-meter to measure capacitance between the terminals of one capacitor at a time. If the capacitance of either is below the **50% Capacitance** value in **Table 26**, contact Phase Technologies for replacement.

For **PT Medium** and **Large Frames**, disconnect wires from L2 and use a multi-meter to measure between L1 and L2, then measure between L2 and L3. If either capacitance measured is below the **50% Capacitance** value in **Table 26**, contact Phase Technologies for replacement.

Table 26 – PT Nominal Filter Capacitor Values in MicroFarads (uF)

Converter Model	Nominal Capacitance	50% Capacitance
PT407, PT410, PT415, PT420	10 uF	5 uF
PT007, PT430	10 uF	5 uF
PT010, PT020	20 uF	10 uF
PTE007, PTE007QT, PTE010, PTE010QT, PTE015, PTE020, PTE407, PTE407QT PTE410, PTE410QT, PTE415QT, PTE420QT	20 uF	10 uF
PTE207QT, PTE210QT, PTE215QT, PTE220QT	20 uF	10 uF
PT030, PT040, PT440, PT450, PT460, PT475	40 uF	20 uF
PT050, PT060, PT075, PT4100	80 uF	40 uF

For **240V and voltage doubling PTE models (PTE0XX and PTE2XX)**, disconnect wires from JL2 and use a multi-meter to measure between JL1 and JL2, then measure between JL2 and JL3B. If either capacitance measured is below the **50% Capacitance** value in **Table 26**, contact Phase Technologies for replacement.

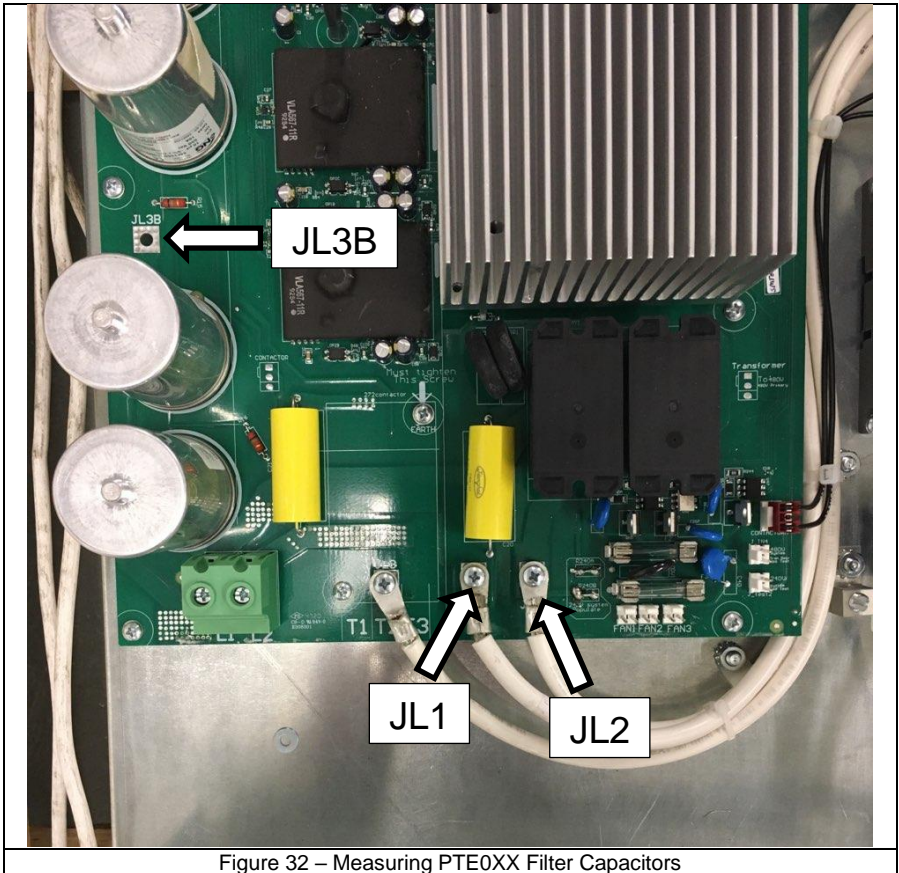


Figure 32 – Measuring PTE0XX Filter Capacitors

For **480V PTE models (PTE4XX)**, disconnect wires from JL2. You may need to remove the baffle covering the heatsink to access JL2. Next, use a multi-meter to measure between L1 and L2, then measure between L2 and JL3B. If either capacitance measured is below the **50% Capacitance** value in **Table 26**, contact Phase Technologies for replacement. Be sure to reconnect wires to JL2 before powering unit on again.

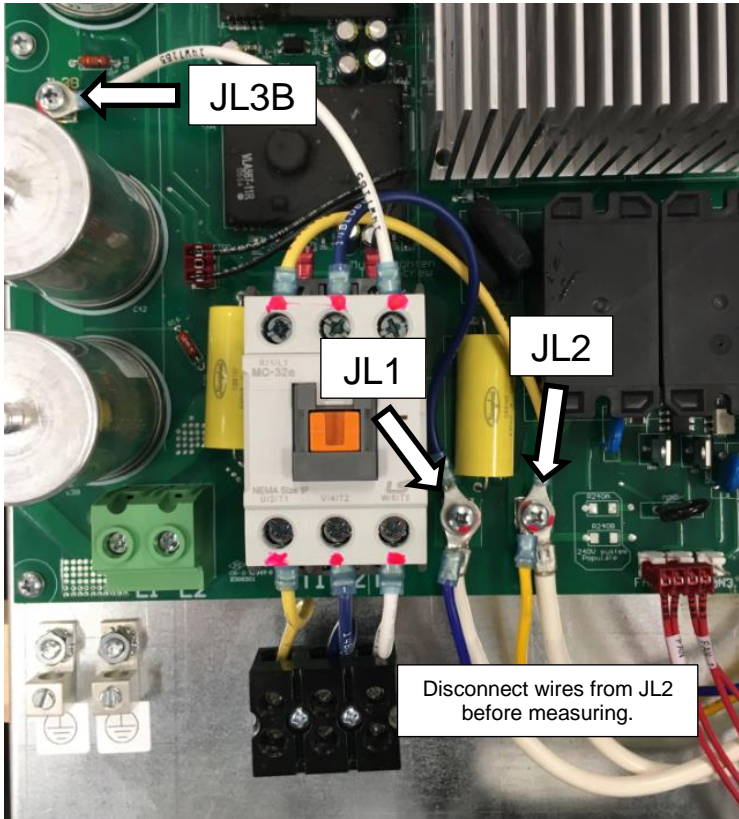


Figure 33 – Measuring PTE4XX Filter Capacitors

Fuses

There are several replaceable fuses in the converter. Each fuse is assigned a designator, indicated by its label. Contact the Phase Technologies Service Department for replacement fuses.

Table 27 – Fuse Information

Fuse Designator	Locations	250 V Fuse Rating
F1	Inverter Board	3 A Fast Blow
F3	Inverter Board	3 A Fast Blow

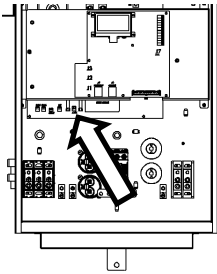


Figure 34 – PT Small Frame Fuse Location

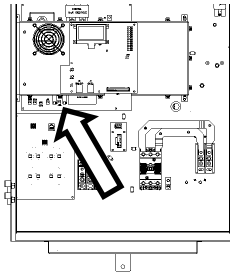


Figure 35 – PT Medium Frame Fuse Location

Small Frame Models:
 PT407, PT410, PT415,
 PT420

Medium Frame Models:
 PT007, PT010, PT020,
 PT430

Large Frame Models:
 PT030, PT040, PT050,
 PT060, PT075, PT440,
 PT450, PT460, PT475,
 PT4100

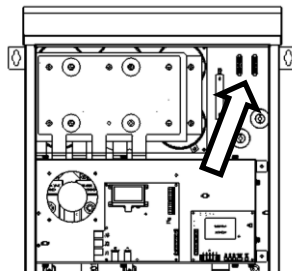
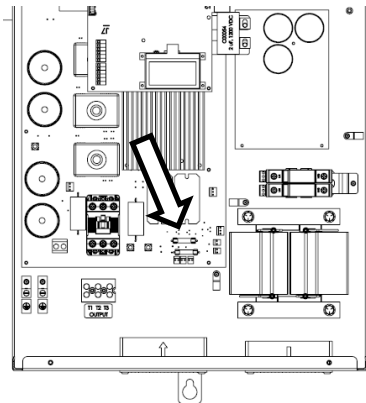


Figure 36 – PT Large Frame Fuse Locations

Some PTE models may require the heat sink baffle to be removed before accessing fuses. To do this, remove the screws fastening the baffle to the side of the heatsink.

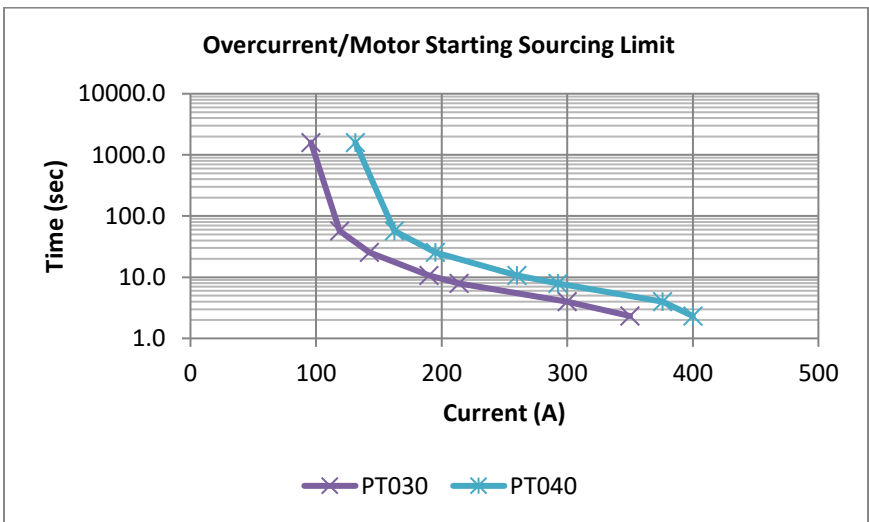
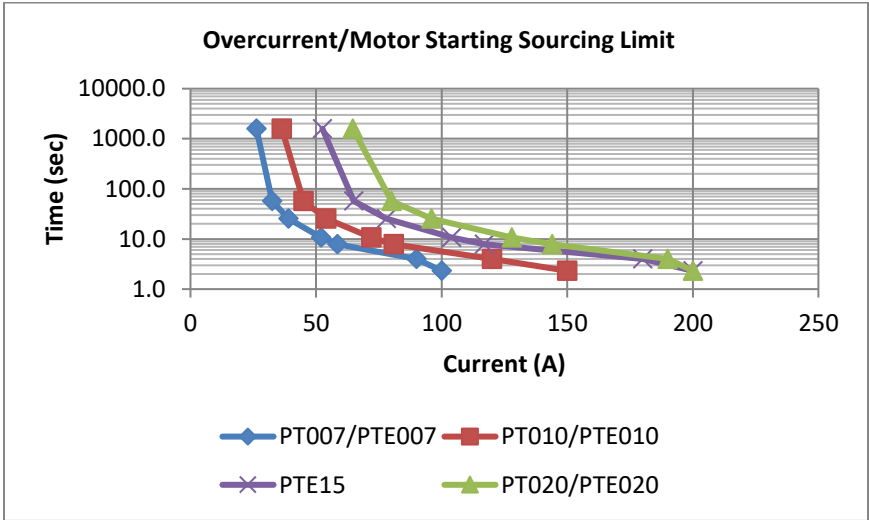
The heat sink baffle is necessary for proper cooling and must be replaced before resuming operation. If not properly replaced, warranty may be voided.

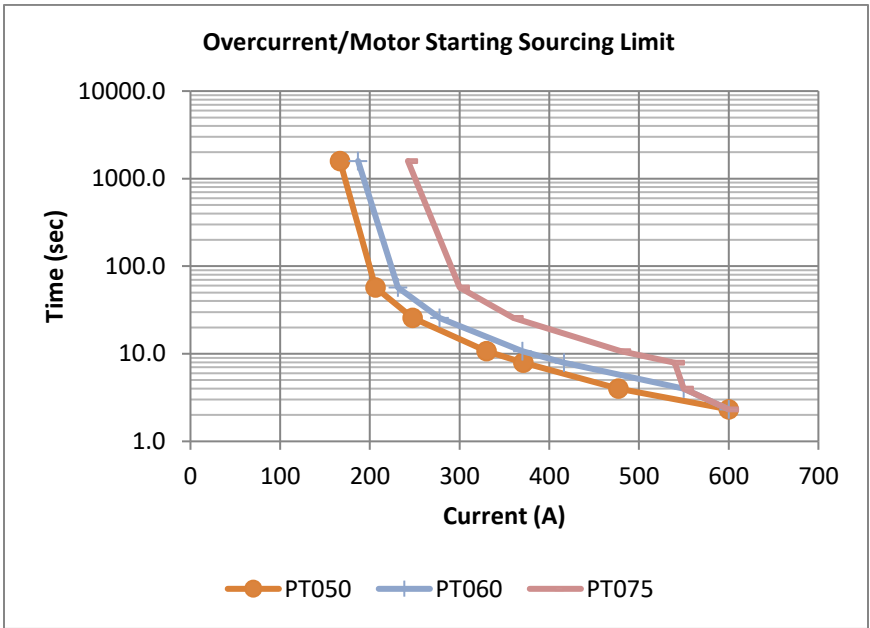


**Figure 37 – PTE Frame 2 Fuse Location
 (Heat Sink Baffle Must Be Removed)**

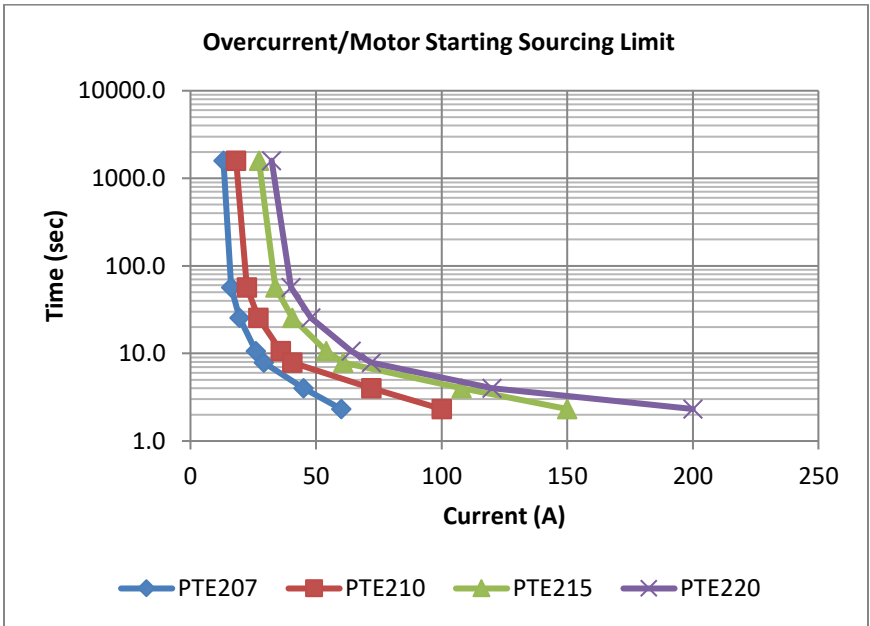
MOTOR STARTING/OVERLOAD CAPABILITIES

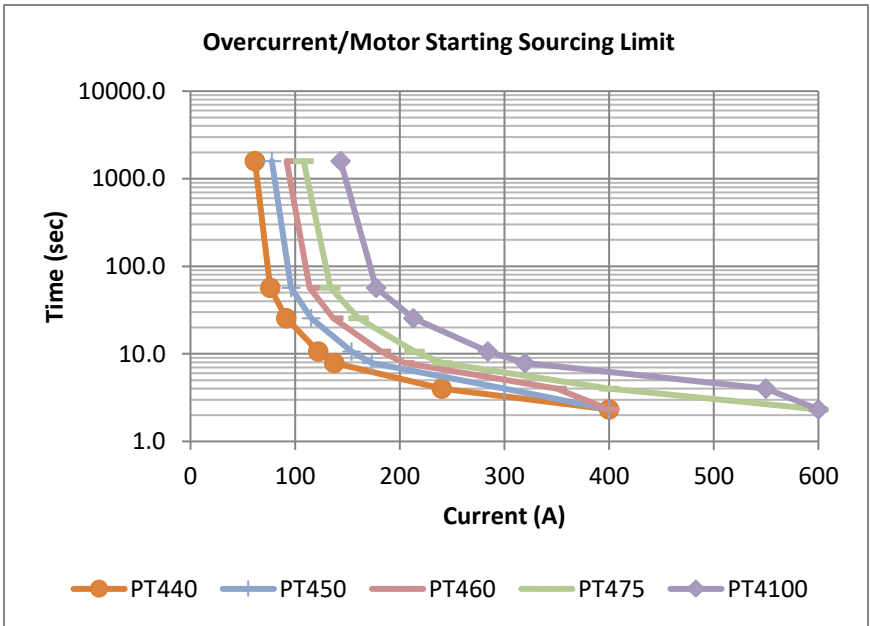
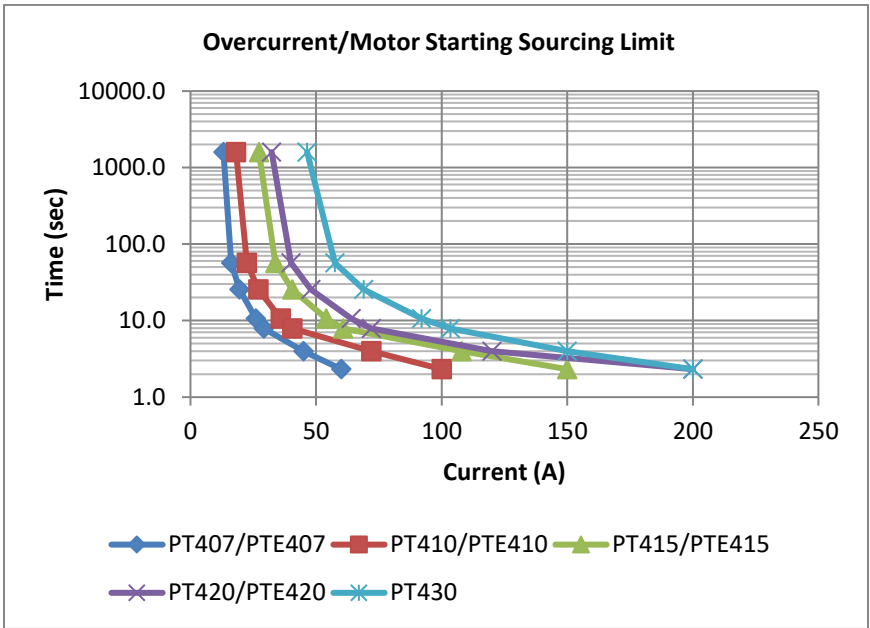
All Phase Perfect digital phase convertors are rated to across the line start motors up to the nameplate horsepower rating of the convertor except for 50 HP models and larger. Motor starting capability is approximately equivalent to an across the line starter using a Class 10 thermal overload. This capability is accomplished using a Class 4 thermal overload characteristic with a proprietary algorithm that limits inrush current on the manufactured leg during startup to prevent nuisance tripping. During startup, voltage is folded back when current exceeds 400% of Full Load Amps (FLA) of the convertor. Below 400% of FLA, a Class 4 thermal overload curve and thermal measurements, on the IGBTs, control overload tripping.





*PT050, PT060, and PT075 should not be used to cross-the-line-start motor loads.





*Phase converters 50 HP and larger should not be used to cross-the-line start motor loads.



LIMITED WARRANTY

This Limited Warranty applies to the following
Phase Technologies' product lines:

Phase Perfect® Digital Phase Converters One Year Warranty

Phase Perfect Digital Phase Converters are warranted against defects in material and workmanship. This warranty covers both parts and labor from the date of purchase from Phase Technologies. Phase Technologies will repair or replace (at our option), at no charge, any part(s) found to be faulty during the warranty period specified. The warranty repairs must be performed by/at a Phase Technologies Authorized Service Center or at Phase Technologies LLC, Rapid City, SD.

Obligations of Customer

1. The original Bill of Sale must be presented in order to obtain "in-warranty" service. Transportation to Phase Technologies or an Authorized Service Center is the responsibility of the purchaser. Return transportation is provided by Phase Technologies.
2. Installations must comply with all national and local electrical codes.

Exclusions of the Warranty

This warranty does not cover any of the following: accident, misuse, fire, flood, and other acts of God. Nor does this warranty cover any contingencies beyond the control of Phase Technologies, LLC, including: water damage, incorrect line voltage, improper installation, missing or altered serial numbers, and service performed by an unauthorized facility.

Phase Technologies' liability for any damages caused in association with the use of Phase Technologies' equipment shall be limited to the repair or replacement only of the Phase Technologies' equipment. No person, agent, distributor, dealer, or company is authorized to modify, alter, or change the design of this merchandise without express written approval of Phase Technologies, LLC.

Installations must comply with all national and local electrical code requirements.



222 Disk Drive, Rapid City, SD 57701

866-250-7934 - Toll-Free 605-343-7934 - Main

www.phasetechnologies.com
