

# SEWAGE PUMPS

## Model: SWF200



### Features

- Heavy duty cast iron construction
- Oil-filled continuous duty PSC motor (1Ph) and Induction motor (3Ph)
- Semi-open cast iron impeller
- 2" solids handling

### Specifications

#### Physical Data:

DISCHARGE SIZE	2" Flanged with 2" & 3" NPT Adapter
IMPELLER TYPE	2-Vane Semi-open - Cast Iron
CABLE LENGTH	20'

#### Liquid Handling:

SOLIDS SIZE	2"
MAXIMUM LIQUID TEMP.	104°F – Intermittent
ACCEPTABLE PH RANGE	6-8

#### Technical Data:

MOTOR HOUSING	Cast Iron
CASING	Cast Iron
IMPELLER	Cast Iron
MOTOR SHAFT	SS430
HARDWARE	SST
"O" RINGS	NBR
SEALS	Single Mechanical, Carbon Ceramic
UPPER BEARING	6203
LOWER BEARING	6203

#### Electrical Data:

R.P.M.	1750
MOTOR TYPE	PSC/Induction
GEN INSULATION CLASS	B
STATOR WINDING CLASS	B
MAXIMUM STATOR TEMP	130°C
VOLTAGE TOLERANCE	±10%
MOTOR PROTECTION	Thermally Protected
HP	2
VOLTAGE	208/230/460
PHASE	1/3
SERVICE FACTOR	1

### Specifications

Model	HP	Hz	Volts/Ph	RPM	Full Load Amps	Nema Start Code	Cord Type	Cord Power Size	Cord O.D.
SWF200M2-20	2	60	230/1	1750	16.7	K	SOW	12AWG/3C	.62
SWF200M3-20	2	60	230/3	1750	11.0	L	SOW	14AWG/4C	.59
SWF200M4-20	2	60	460/3	1750	5.5	L	SOW	14AWG/4C	.59
SWF200M5-20	2	60	208/1	1750	21.0	L	SOW	12AWG/3C	.62
SWF200M6-20	2	60	208/3	1750	11.5	L	SOW	14AWG/4C	.59

# Features

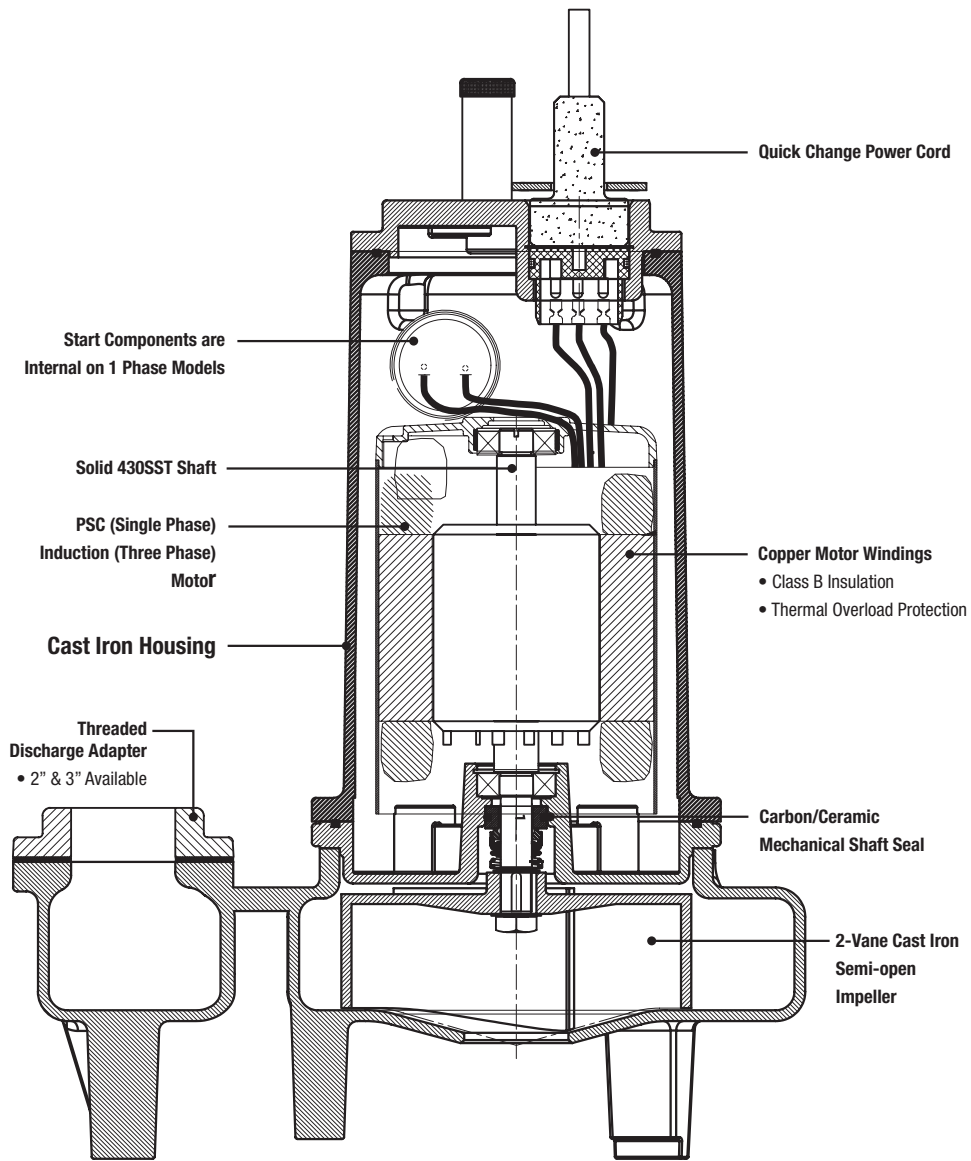

## Dimensions

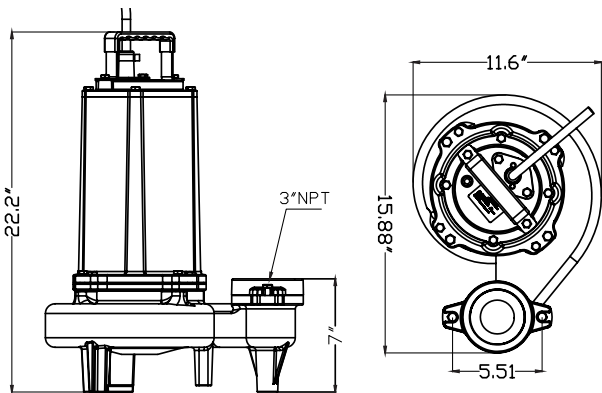

## Performance Curve

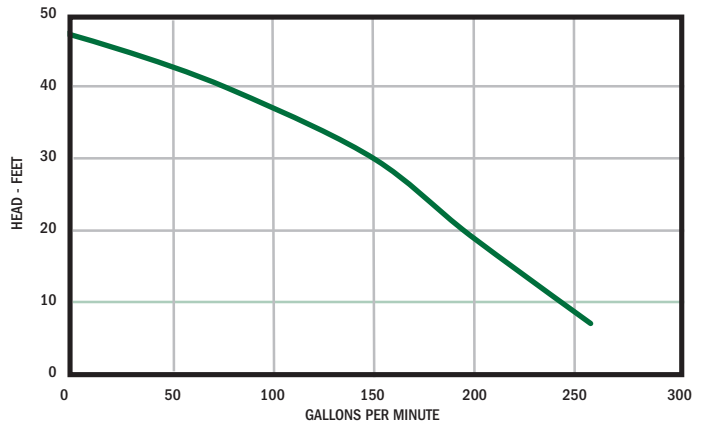

P U M P

*Honest, Professional, Dependable*

1899 Cottage Street, Ashland, Ohio 44805

Telephone: 855 281-6830 • Fax: 877 326-1994 • ashlandpump.com