

SEWAGE PUMPS

Model: SWFD200



Features

- Heavy duty cast iron construction
- Oil-filled continuous duty PSC motor (1Ph) and Induction motor (3Ph)
- Semi-open cast iron impeller
- 2" solids handling

Specifications

Physical Data:

DISCHARGE SIZE	2" Flanged with 2" and 3" NPT Adapter
IMPELLER TYPE	2-Vane Semi-open- Cast Iron
CABLE LENGTH	20'

Liquid Handling:

SOLIDS SIZE	2"
MAXIMUM LIQUID TEMP.	104°F – Intermittent
ACCEPTABLE PH RANGE	6-8

Technical Data:

MOTOR HOUSING	Cast Iron
CASING	Cast Iron
IMPELLER	Cast Iron
MOTOR SHAFT	SS416
HARDWARE	SST
"O" RINGS	NBR
SEALS	Single Mechanical, Carbon Ceramic
UPPER BEARING	6203
LOWER BEARING	6203

Electrical Data:

R.P.M.	1750
MOTOR TYPE	PSC/Induction
GEN INSULATION CLASS	B
STATOR WINDING CLASS	B
MAXIMUM STATOR TEMP	130°C
VOLTAGE TOLERANCE	±10%
MOTOR PROTECTION	Thermally Protected
HP	2
VOLTAGE	208/230/460
PHASE	1/3
SERVICE FACTOR	1

Specifications

Model	HP	Hz	Volts/Ph	RPM	Full Load Amps	Nema Start Code	Cord Type	Cord Power Size	Cord O.D.
SWFD200M2-20	2	60	230/1	1750	16.7	P	SOW	12AWG/3C	.62
SWFD200M3-20	2	60	230/3	1750	11.0	P	SOW	14AWG/4C	.59
SWFD200M4-20	2	60	460/3	1750	5.5	P	SOW	14AWG/4C	.59
SWFD200M5-20	2	60	208/1	1750	21.0	P	SOW	12AWG/3C	.62
SWFD200M6-20	2	60	208/3	1750	11.5	P	SOW	14AWG/4C	.59

Features

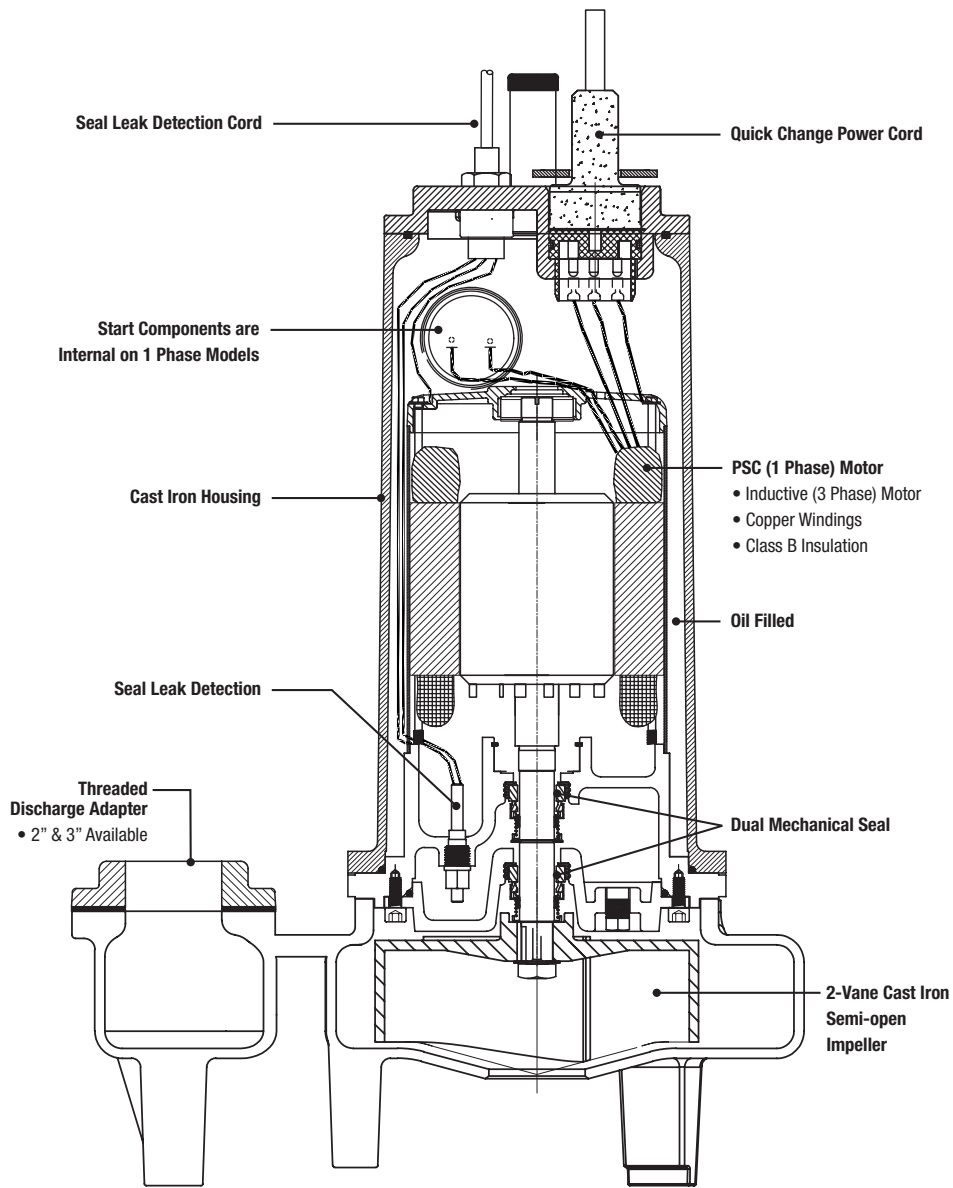

Dimensions

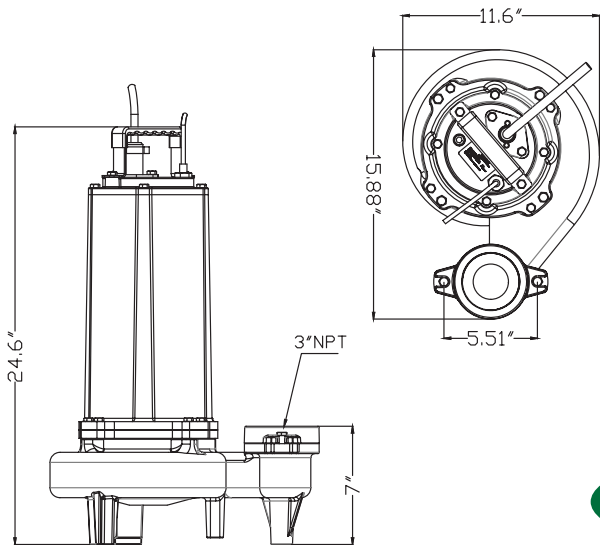

Performance Curve

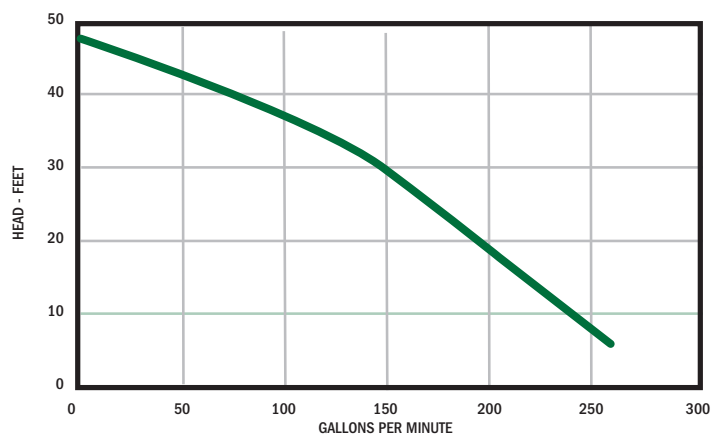

P U M P

Honest, Professional, Dependable

1899 Cottage Street, Ashland, Ohio 44805

Telephone: 855 281-6830 • Fax: 877 326-1994 • ashlandpump.com