

# INSTALLATION AND GENERAL INSTRUCTIONS

## INSTALLATION

1. L1 and L2 shall be connected to rotary phase converter through appropriate disconnect switch.
2. Three phase output can be connected through fused safety switch or breaker panel, before distribution to various three phase motors.

## CAUTION

1. Never connect T3 (manufactured phase) to magnetic or computerized controls or any single phase application. Fluctuating voltage will produce unsatisfactory operation of those applications.
2. Converter must be started before load is applied

## NOTICE

1. Use chart to determine wire and fuse size. (see chart below)
2. Improper wire sizes will cause poor converter performance.

MODEL	LARGEST MOTOR HP	COMBINED TOTAL HP	1 PHASE INPUT*		3 PHASE OUTPUT
			BREAKER	WIRE	
RPC 3/4-2	3/4	2	15A	#14	<b>1. THREE PHASE OUTPUT wire guage shall be determined by amperage of applied load.</b>
RPC 2-6	2	6	30A	#10	
RPC 3-9	3	9	50A	#8	
RPC 5-15	5	15	60A	#6	
RPC 7.5-20	7.5	20	80A	#4	
RPC 10-30	10	30	100A	#1	
RPC 15-45	15	45	150A	#2/0	
RPC 20-60	20	60	200A	#2/0	
RPC 25-75	25	75	250A	#250MCM	

**\*Use these suggested wire and breaker ratings for maximum converter output, or size according to combined total motor horsepower load.**

## CONNECTION DIAGRAM

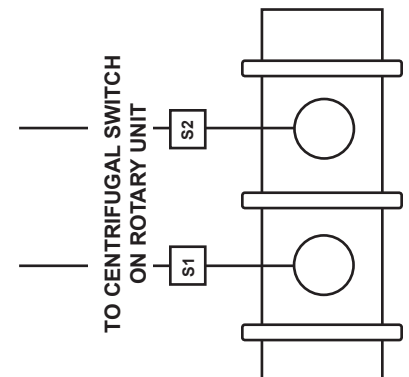
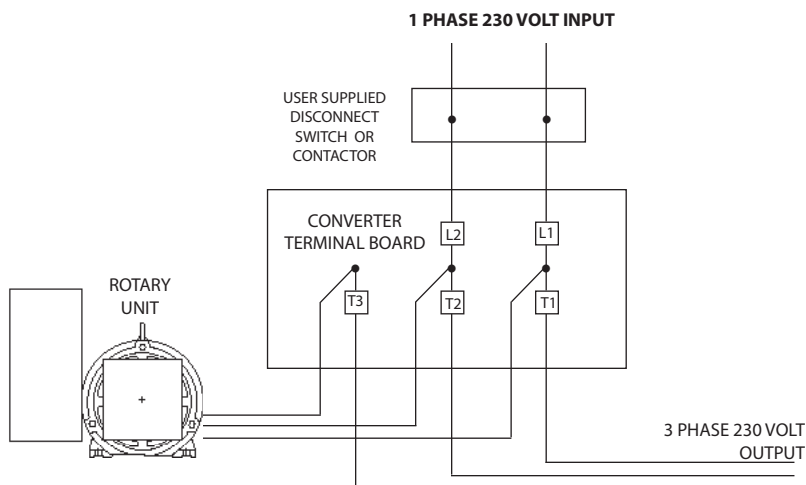

**IMPORTANT** For best performance and trouble free operation, converter should be installed in a relatively clean and dry location!