



SERVICE PARTS LIST

BULLETIN NO.
54-40-8020

SPECIFY CATALOG NO. AND SERIAL NO. WHEN ORDERING PARTS		REVISED BULLETIN	DATE
M18 FUEL™ Compact Bandsaw w/ two handed actuation			Feb. 2020
CATALOG NO. 2829S-20	STARTING SERIAL NO. L23A	WIRING INSTRUCTION See Page 3	

EXAMPLE:
Component Parts (Small #) Are Included
When Ordering The Assembly (Large #).

NOTE: Use of this bandsaw is not recommended on bandsaw tables.

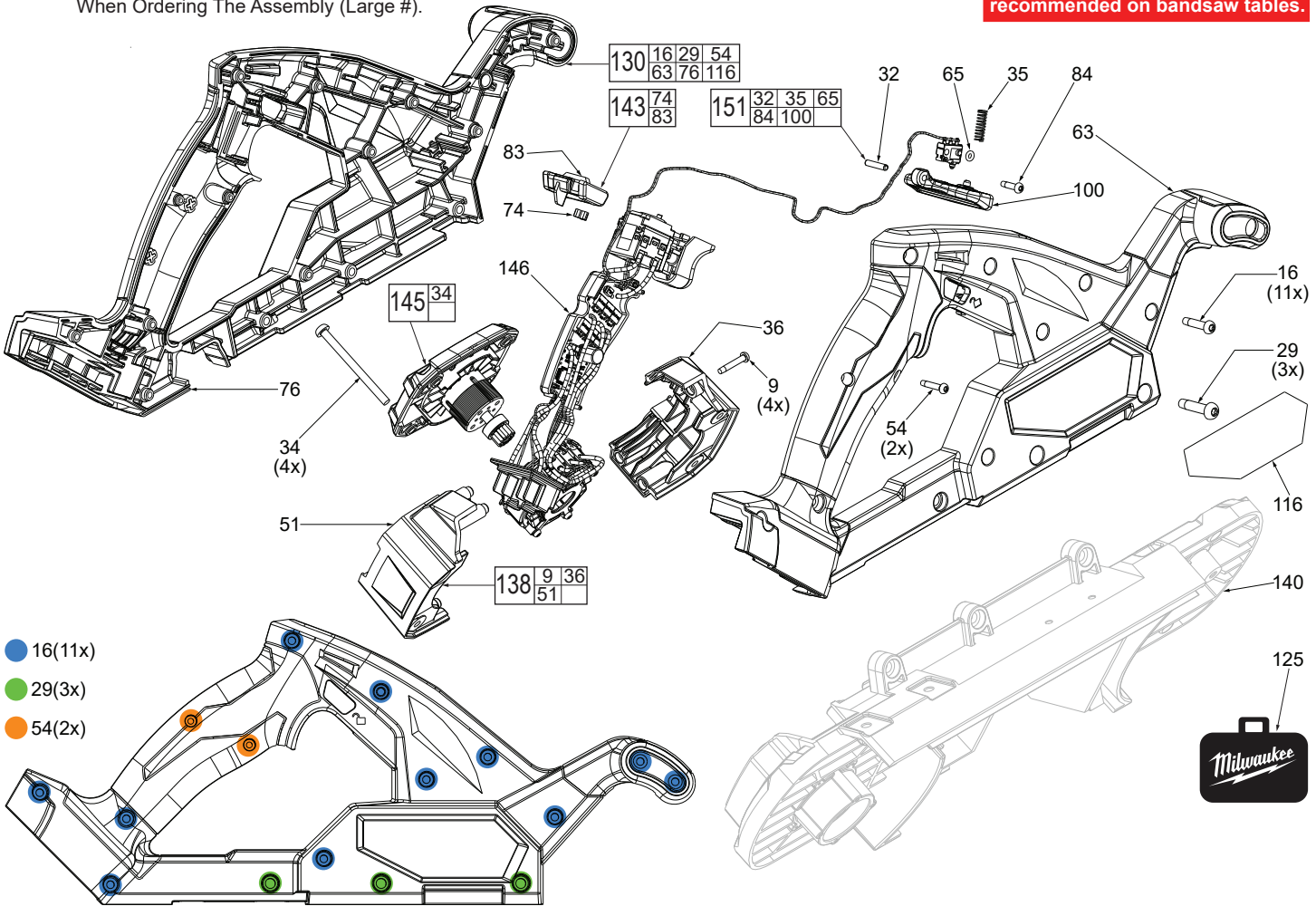

FIG.	PART NO.	DESCRIPTION OF PART	NO. REQ.
9	05-88-0780	M3 x 18mm Pan Hd. ST T-10 Screw	(4)
16	06-82-0044	M4 x 18mm Pan Hd. ST T-20 Screw	(11)
29	05-74-0038	M5 x 22mm Pan Hd. ST T-25 Screw	(3)
32	-----	Pin	(1)
34	05-78-0012	M4 x 52mm Pan Hd. T-20 Machine Screw	(4)
35	-----	Spring	(1)
36	-----	Motor Cover - Left	(1)
51	-----	Motor Cover - Right	(1)
54	06-82-6351	M3 x 16mm Pan Hd. ST T-10 Screw	(2)
63	-----	Right Housing Halve - Cover	(1)
65	-----	O-Ring	(1)
74	40-50-0665	Detent Spring	(1)
76	-----	Left Housing Halve - Support	(1)
83	-----	Lock On/Off Switch	(1)
84	06-82-1087	M3 x 12mm Pan Hd. ST T-10 Screw	(1)
100	-----	Switch Paddle for T-Handle	(1)
116	12-20-2829	Service Nameplate	(1)
125	50-55-3560	Contractor Bag	(1)
130	14-34-0034	Housing Halve Kit	(1)
138	31-13-0097	Motor Cover Kit	(1)
140	14-30-0032	Pulley Support Deck Assembly with Bushing and Ball Bearing 02-04-0719	(1)
143	42-42-0064	Lock On/Off Button Kit	(1)
145	16-07-0013	Rotor/Cap Kit	(1)
146	14-20-0141	Electronics Assembly	(1)
151	23-66-0206	Switch Paddle Kit	(1)

SCREW TORQUE SPECIFICATIONS				
FIG.	PART NO.	WHERE USED	SEAT TORQUE	
			(KG/CM)	(IN/LBS)
1	-----	LED/LED Housing	5-7	4-6
6	05-78-0910	Rafter Hook Kit	8-10	7-8
9	05-88-0780	Motor Cover - Left	8-10	7-8
16	06-82-0044	Right Housing Halve	20-23	17-20
26	-----	Gearbox Kit	7-9	6-8
27	-----	LED Housing	5-7	4-6
28	-----	Output Shaft Ret. Plate	14-21	12-18
29	05-74-0038	Right Housing Halve	27-33	23-28
31	06-82-5574	Guide Roller Kits	31-37	27-32
34	05-78-0012	Rotor/Cap Kit	17-22	14-19
43	06-82-5314	Front and Rear Shroud	29-34	25-29
48	06-81-0075	Tensioning Mechanism	20-25	17-21
49	06-82-5346	Tire Clean Brush Cover	19-25	16-21
54	06-82-6351	Right Housing Halve	6-9	5-8
61	06-82-5330	Shoe Kit	36-44	31-38
70	06-75-0035	Tensioning Mechanism	80-120	69-104
79	06-82-0040	Front and Rear Pulley	85-95	73-82
81	06-82-0150	Tension Lever	25-30	21-26
84	06-82-1087	T-Handle Micro Switch	3-4	2-3

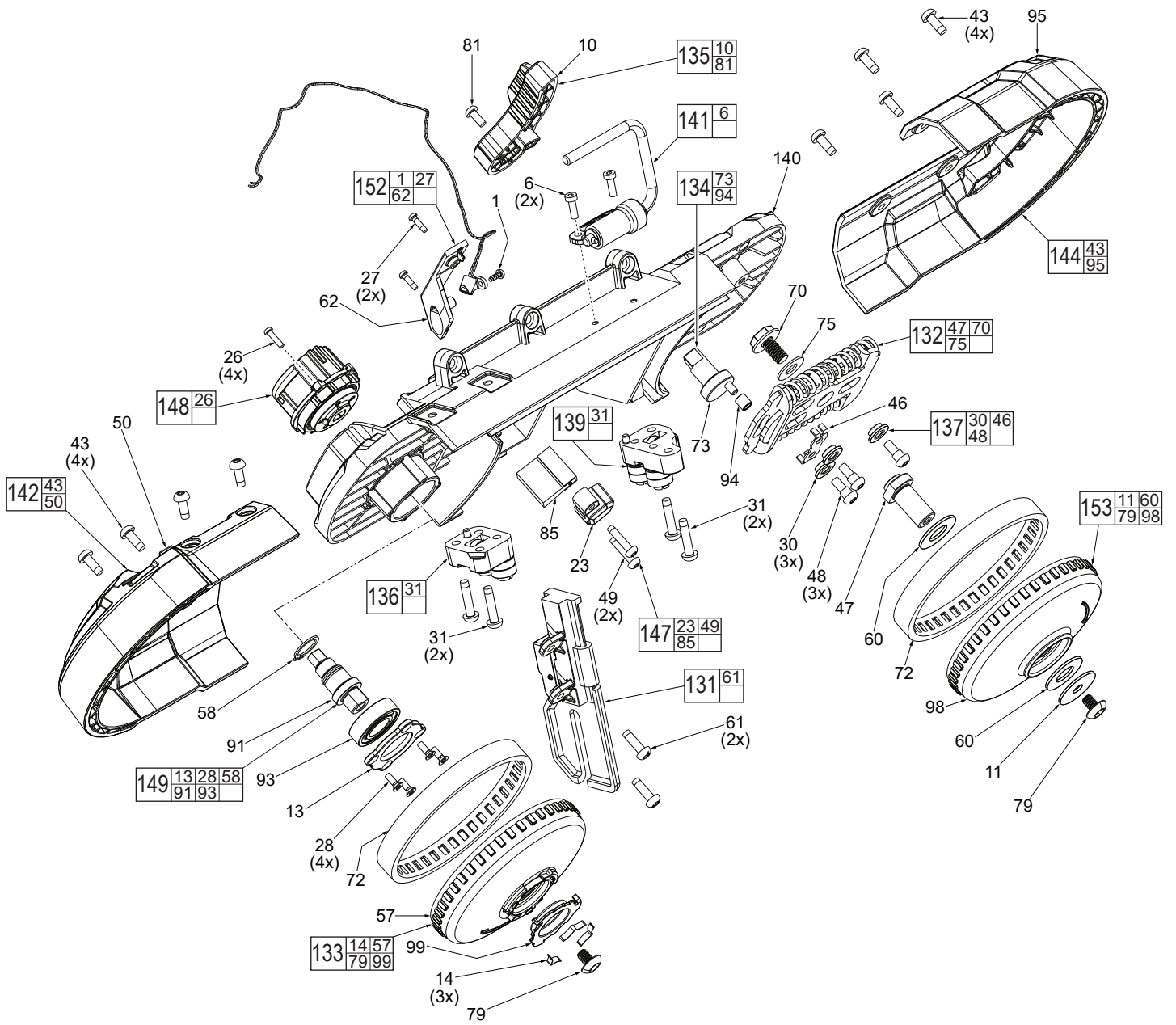

FIG.	PART NO.	DESCRIPTION OF PART	NO. REQ.
1	-----	M3 x 8mm Pan Hd. ST T-10 Screw	(1)
6	05-78-0910	M4 x 12mm Cap Hd. Hex Socket Screw	(2)
10	-----	Tension Lever	(1)
11	45-88-0832	Washer	(1)
13	-----	Output Shaft Retaining Plate	(1)
14	-----	Reamer Detent Spring Plate	(3)
23	-----	Tire Cleaning Brush Cover	(1)
26	-----	M3 x 12mm Pan Hd. T-10 Machine Screw	(4)
27	05-81-0005	M3 x 11mm Pan Hd. Taptite T-10 Screw	(2)
28	05-88-1204	M3.5 x 10mm Flat Hd. T-15 Mach. Screw	(4)
30	-----	Tension Bushing	(3)
31	06-82-5574	10-24 x 22mm Pan Hd. Taptite T-25 Screw	(4)
43	06-82-5314	10-24 x 12" Pan Hd. Taptite T-25 Screw	(8)
46	-----	Wear Plate	(1)
47	-----	Front Pulley Axle	(1)
48	06-81-0075	10-32 UNF-3A Pan Hd. T-25 Mach. Screw	(3)
49	06-82-5346	8-32 x 19mm Pan Hd. Tapt. T-20 Screw	(2)
50	-----	Rear Shroud	(1)
57	-----	Rear Pulley with Insert Bushing	(1)
58	-----	Retaining Ring	(1)
60	45-88-0545	Rubber Washer	(2)
61	06-82-5330	10-32 x 16mm Pan Hd. Tapt. T-25 Screw	(2)
62	-----	LED Housing	(1)
70	06-75-0035	5/16-18 x 9/16" CWH Hex Recess Screw	(1)
72	45-96-0050	Pulley Tire	(2)
73	-----	Cam	(1)
75	-----	Washer	(1)

FIG.	PART NO.	DESCRIPTION OF PART	NO. REQ.
79	06-82-0040	1/4-20-UNC-2A x 9mm TH Hex Screw	(2)
81	06-82-0150	8-32 x 10mm Pan Hd. Taptite T-20 Screw	(1)
85	-----	Tire Cleaning Brush	(1)
91	-----	Output Shaft	(1)
93	-----	Ball Bearing	(1)
94	-----	Cam Bushing	(1)
95	-----	Front Shroud	(1)
98	-----	Front Pulley	(1)
99	-----	Reamer Retaining Washer	(1)
131	45-16-0012	Shoe Kit	(1)
132	42-28-0027	Tensioning Mechanism Assembly	(1)
133	28-95-0016	Rear Pulley Kit	(1)
134	42-09-0021	Tension Cam Kit	(1)
135	42-09-0018	Tension Lever Kit	(1)
136	42-24-0024	Rear Guide Roller Kit	(1)
137	42-09-0023	Tensioning Screw Kit	(1)
139	42-24-0022	Front Guide Roller Kit	(1)
140	14-30-0032	Pulley Support Deck Assembly with Bushing and Ball Bearing 02-04-0719	(1)
141	14-34-0036	Rafter Hook Kit	(1)
142	31-15-0071	Rear Shroud Kit	(1)
144	31-15-0074	Front Shroud Kit	(1)
147	14-46-0176	Tire Brush Kit	(1)
148	14-29-0023	Gearbox Kit	(1)
149	14-73-0011	Output Shaft Assembly	(1)
152	44-06-0064	LED Housing Kit	(1)
153	28-95-0021	Front Pulley Kit	(1)

As an aid to reassembly, take notice of wire routings and position in wire guides and traps while dismantling tool.

Be sure that all components of the electronics kit are seated firmly and squarely in the housing recesses.

Avoid pinched wires, be sure that all wires and sleeves are pressed completely down in wire guides and traps.

Prior to securing the housing cover onto the housing support, be sure that there are no interferences.

Before installing the battery, check for proper functionality of shuttle and triggers.

Install battery and depress switch triggers to assure tool is operating properly.

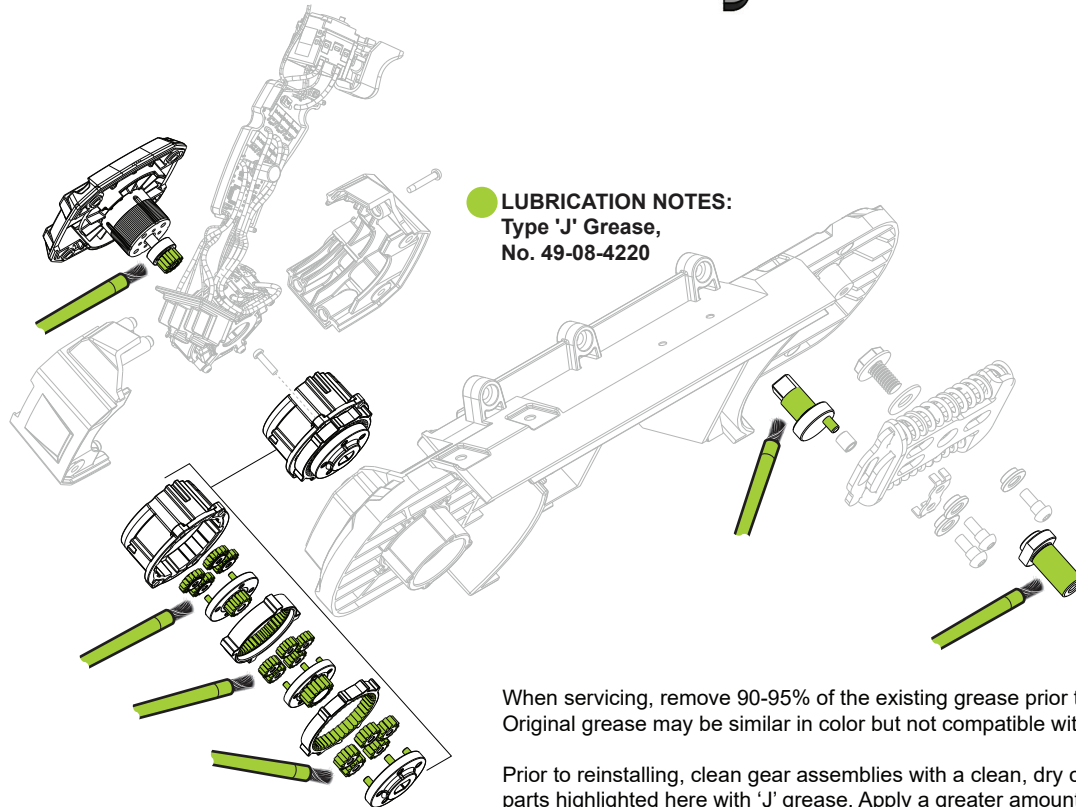
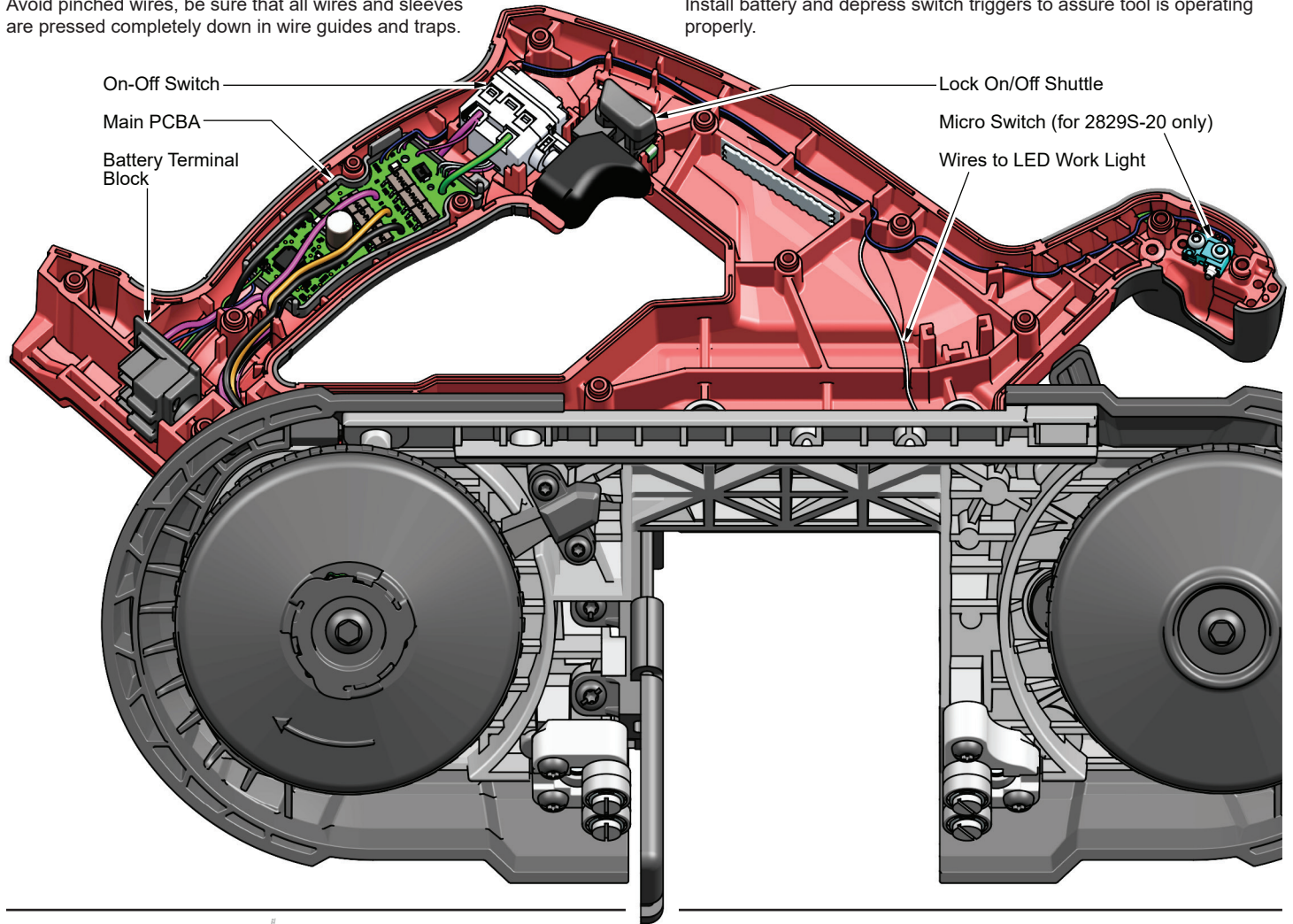

When servicing, remove 90-95% of the existing grease prior to installing Type 'J'. Original grease may be similar in color but not compatible with 'J'.

Prior to reinstalling, clean gear assemblies with a clean, dry cloth. Lightly coat all parts highlighted here with 'J' grease. Apply a greater amount of grease to all gear teeth.